

2019

A Network Theory Approach to Global Legislative Action

Nadia Banteka
Florida State University

Follow this and additional works at: <https://ir.law.fsu.edu/articles>



Part of the Law Commons

Recommended Citation

Nadia Banteka, *A Network Theory Approach to Global Legislative Action* *Seton Hall Law Review* 339 (2019),
Available at: <https://ir.law.fsu.edu/articles/741>

This Article is brought to you for free and open access by Scholarship Repository. It has been accepted for inclusion in Scholarly Publications by an authorized administrator of Scholarship Repository. For more information, please contact efarrell@law.fsu.edu.

A Network Theory Approach to Global Legislative Action

*Nadia Banteka**

I. INTRODUCTION	340
II. HOW NETWORKS MAKE US SEE THE LEGAL SYSTEM DIFFERENTLY ...	342
A. Introducing Networks: From Kant to Facebook	342
B. The Different Lens of Networks	345
C. Networks in the International Legal System	348
D. Potential Objections Against Networks	355
1. The “Subjects” Doctrine	356
2. Questions of Legitimacy	358
3. Questions of Accountability	362
III. MANNERS OF CONNECTION IN NETWORKS	365
A. Short Introduction to Network Theory and Analysis	365
B. Why International Law, Why Now?	370
1. The Basic Network Properties	372
2. The Basic Network Metrics	376
i. Centrality	376
ii. Connectivity	382
a. Density	384
b. Transitivity / Clustering Coefficient	386
iii. Similarity or Equivalence	387
iv. The Basic Network Topologies	391
a. Point-to-Point Network	391
b. Hub-and-Spoke Network	394
c. Cliques	397
IV. CONCLUSION & NEXT RESEARCH STEPS	397

* Visiting Assistant Professor, Villanova University Charles Widger School of Law; Visiting Fellow, Yale Law School. I would like to thank William Burke-White, William Ewald, Jacques DeLisle, Jean Galbraith, Beth Simmons, Hans Peter Kohler, Erika Nyborg-Burch, and the participants of the Penn Conference on International Law and International Relations for their valuable feedback on earlier drafts. Thank you also to Svetlana Atanasova, Olivia Flasch, and Rohan Jain for their excellent research assistance. Finally, thank you to the editors of Seton Hall Law Review for their valuable and constructive input. All remaining errors are my own.

I. INTRODUCTION

Current societies are far more interconnected than societies have ever been in the past.¹ With the advances of technology and infrastructure, networks have quickly become an integral part of our daily lives. A modern city would struggle to function without networks of waste management; sewers; power grids; water pipelines; transportation; distribution of goods, food, or services; health care; education; telecommunications; and banking.² Most of these networks often span regionally and globally, generating networks of networks through an engineered “webbing of humanity.”³ When we update our status on Facebook, tweet, or share instant messages through mobile networks or communication apps on our smartphones, we are entangled in this web and proliferate it. We aim to find jobs, friends, lovers, and spouses through networks engineered to computationally match the data that we provide. But networks do not only exist in the external world. Our physiological construction operates through naturally occurring networks. Brain development and function represent a highly complex, integrated network of signaling and communication among neurons and other nerve cells, muscles, or gland cells. Proteins interact with other proteins in protein interaction networks.⁴

This is the story of networks. It is a fascinating tale that reaches across centuries and has become an important part of our lives, our communities, and of the world. As networks continue to occupy an ever-larger space in our daily realities, we need to understand them better than we currently do. But despite or, perhaps, due to the embeddedness of networks in our physical, virtual, and physiological worlds, we are often unaware of their existence in legal systems—it is as if they are hidden in plain sight. Even when we see them, we sometimes become oblivious to their operation or salience due to our preexisting systemic perceptions and mental blind spots. The Society of Automotive Engineers (SAE) has suggested that, unlike popular belief, the outside mirrors in a car can be adjusted to eliminate blind spots.⁵ When correctly positioned, the mirrors negate a car’s blind spots. The only problem is getting used to the SAE-recommended mirror positions. Similarly, with our mental blind spots,

¹ See generally COMMITTEE ON NETWORK SCIENCE FOR FUTURE ARMY APPLICATIONS ET AL., NETWORK SCIENCE 7 (2005).

² BRUCE J. WEST & NICOLA SCAFETTA, DISRUPTED NETWORKS: FROM PHYSICS TO CLIMATE CHANGE 7 (2010).

³ *Id.*

⁴ Trey Ideker et al., *Discovering Regulatory and Signaling Circuits in Molecular Interaction Networks*, 18 BIOINFORMATICS S233 (2002).

⁵ George Platzer, *The Geometry of Automotive Rearview Mirrors - Why Blind Zones Exist and Strategies to Overcome Them*, SAE TECHNICAL PAPER 143 (1995).

training our “mental eyes” to see the world in networks will hopefully allow us to ease into seeing the international system in its networks too.

The purpose of this article is twofold. First, it aims to systematize some of the understandings that other disciplines have to offer in bringing together a set of “best practices” that will guide future research in recognizing, mapping, and utilizing networks in legislative action, and international legislative action in particular. Second, it will provide a methodological framework of analysis and introduce a set of tools that will improve our understanding of contemporary international legislative action.

In Part II of this article, I propose that we re-conceptualize the international legal system through a networks perspective. I address first the different analytic lens that networks provide by looking at the ways various actors generally connect; how different patterns of connection yield different types of networks; and how the position, quantity, and quality of ties an actor has with other actors in the network determines leadership, influence, power, and effect within the network, but also of the network itself. Then, I discuss how networks have emerged as salient structures in the international system and juxtapose this development to existing state-centric perspectives of this system. The purpose of this part is to show how we can learn to see the international system in networks. This part of the Article captures an international reality in which states still retain their agency as important actors, while also connecting with other states and non-state actors through a multiplicity of networks. In this world, states, government officials, agencies, international organizations, NGOs, corporations, and even individuals, all create networks that influence the international system, and each participant is capable of operating as a distinct actor within these networks towards legislative action.

In Part III of the Article, I introduce a methodological framework for the study of networks as structures, examining their role and impact on the making of international law. I put forward the main metrics of this framework based on social network analysis, its quantitative tools but also its limitations, to examine how agents connect and behave in small or large groups of actors that introduce, adopt, or dissolve international norms. This insight provides us with a tool to quantify and map actors’ and networks’ contributions to international legislative processes as well as interpret the elusive global realities that lead to international law making. It allows us to understand the wide spectrum of actors, structures, and designs involved in international law making and offers a way to quantify the impact and effect of these actors individually and collectively on the making of international law. Finally, it can help us to tailor networked solutions to our international problems so that international legislative action can be more effective.

II. HOW NETWORKS MAKE US SEE THE LEGAL SYSTEM DIFFERENTLY

A. *Introducing Networks: From Kant to Facebook*

This story of networks begins in Königsberg, a small Russian semi-exclave between Poland and Lithuania on the southeastern corner of the Baltic Sea now called Kaliningrad. The 18th century philosopher Immanuel Kant lived there, when it was still part of the Kingdom of Prussia, and he was known there as Immanuel “the Königsberg clock.”⁶ Kant was renowned for his strict daily routines and his regular walks around the city. While we do not know his exact routine, most likely, on these walks, he would encounter one of Königsberg’s seven famous bridges.

The bridges had spurred an urban riddle known as the “Königsberg bridge problem”: is it possible to walk around the city across all seven bridges without crossing the same bridge twice?⁷ Leonhard Euler, one of the greatest mathematicians of the time, began to solve this enigma. Perhaps without knowing it, Euler developed a new type of mathematics called graph theory. By turning the city into a graph, Euler labeled each of the four land masses surrounding the bridges as nodes, and the bridges as links among those nodes.⁸ By analyzing the structure of the graph, Euler proved that the only way someone could walk across the bridges only once would be if there were an even number of bridges and that, in Königsberg’s seven bridges, such thing would be impossible.⁹ This study introduced the method of graph theory as a way of analyzing networks. And, while we never learned of Kant’s true walking routine, we are now sure of one thing: Kant never crossed all seven bridges without crossing at least one of them twice.

While the seven bridges of Königsberg were the springboard for the emergence of graph theory in spatial networks, the first analysis of a social network took place in New York. In 1932, the New York State Training School for Girls in Hudson approached J. L. Moreno to address an outbreak of fourteen girls running away in two weeks’ time.¹⁰ Instead of addressing each case individually, Moreno mapped all fourteen girls on a graph to

⁶ John Merrick, *Immanuel Kant the, Errrr, Walker?*, VERSO (Apr. 30, 2015), www.versobooks.com/blogs/1963-immanuel-kant-the-errrr-walker.

⁷ Rob Shields, *Cultural Topology: The Seven Bridges of Königsburg, 1736*, 29 THEORY, CULTURE & SOC’Y 43, 44 (2012).

⁸ Leonhard Euler, *Solutio problematis ad geometriam situs pertinentes*, 8 COMMENTARII ACADEMIAE SCIENTIARUM PETROPOLITANAE 128 (1741). See also Gary Chartrand, *The Königsberg Bridge Problem: An Introduction to Eulerian Graphs*, in INTRODUCTION TO GRAPH THEORY 51–66 (1985).

⁹ Euler, *supra* note 8, at 128.

¹⁰ See Diana Jones, *Emotions Mapped by New Geography: Charts Seek to Portray the Psychological Currents of Human Relationships*, N.Y. TIMES, Apr. 3, 1933, at 17.

assess how each influenced the other in bringing about a social “epidemic.” Moreno used network diagrams called “sociograms” to assign students to various residential cottages.¹¹ He found that assignments that considered the results of his sociometric findings substantially reduced the number of runaways from the school.¹²

At P.S. 181 in Brooklyn, Moreno applied his sociograms to observe the relationships between boys and girls in grades kindergarten through eighth grade.¹³ Moreno and his research team recorded the children’s choices of who to sit next to while studying or playing. They then constructed sociograms with triangles representing boys and circles representing girls and the students’ initials in the middle. Moreno’s sociograms from a fourth-grade class indicates that not much has changed in over 80 years within children’s society. The girls are clustered on the one side, the boys on the other, with only one “brave” boy reaching out to one girl to sit next to. The sociogram also indicates an isolated pair of girls that only reached out to each other. A teacher in this class back then or even today could use this sociogram to keep an eye out for classroom interactions, including bullying, while more elaborate analysis could shed light on nuanced classroom dynamics.

Moreno’s sociograms opened the door to further systematization of networks and analysis of their role in our daily lives. But before Moreno, the Hungarian writer Frigyes Karinthy devised a notion of peoples’ proximity in a short fiction story called “Chain Links” in 1929.¹⁴ To demonstrate that people were closer at that time than ever before, Karinthy’s fictional protagonist proposed a test. He bet that his friends could name any person within Earth’s entire population and through at most five friends or acquaintances, one of which he knew personally, he could link himself to this randomly selected person.¹⁵ This idea, also called “the small-world problem,” fascinated social scientists and laymen alike. In the 1950s, two scientists, Ithiel de Sola Pool and Manfred Kochen, set out to test the theory—known as the “small world problem—mathematically.¹⁶ But despite their success in framing the question

¹¹ *Id.*

¹² JACOB L. MORENO, WHO SHALL SURVIVE? FOUNDATIONS OF SOCIOMETRY, GROUP PSYCHOTHERAPY AND SOCIODRAMA 527 (1934).

¹³ *Id.* at 13.

¹⁴ Frigyes Karinthy, *Chain Links*, in THE STRUCTURE AND DYNAMICS OF NETWORKS 21, 22 (Mark Newman et al. eds., 2006).

¹⁵ *Id.*

¹⁶ Charles Korte & Stanley Milgram, *Acquaintance Networks Between Racial Groups: Application of the Small World Method*, 15 J. PERSONALITY SOC. PSYCHOL. 101, 101 (1970) (referencing Ithiel de Sola Pool and Manfred Kochen); Ithiel de Sola Pool & Manfred Kochen, *Contacts and Influence*, 1 SOC. NETWORKS 5, 7 (1978).

mathematically, they were still unable to solve the problem twenty years later.¹⁷

Social psychologist Stanley Milgram undertook a 1967 study that served as the first empirical approach to the small-world problem. Milgram's goal was to test the degrees of separation between any two random individuals in the United States by answering the question of how many acquaintances it took to connect them.¹⁸ He first chose the wife of a divinity graduate student in Sharon, Massachusetts and a stockbroker in Boston, Massachusetts as the two targets of his study. He then chose Wichita, Kansas and Omaha, Nebraska, as the two starting points of the study because "from Cambridge, these cities seem vaguely 'out there,' on the Great Plains or somewhere."¹⁹ At the time, there was nearly no consensus as to how many links it would take to connect people from such remote areas. Milgram wrote, "[r]ecently, when I asked a person of intelligence how many steps he thought it would take, and he estimated that it would require 100 intermediate persons, or more, to move from Nebraska to Sharon."²⁰

Milgram sent letters to these individuals detailing the study and some basic information about either of the two target contact persons in Boston.²¹ He also included a roster on which they would write their own names. Upon receiving these, the volunteers were asked if they personally knew the contact person designated by Milgram in Boston. In the unlikely case that they knew this person, they had to forward the letter directly to them. In the more likely case that they did not know this person, they were asked to think of a friend or a relative whom they knew and was more likely to know the target. They were then asked to sign this person's name on the roster and forward it to them. When the package eventually reached the final target in Boston, the researchers examined the roster to count the number of times the package had been forwarded.²² Milgram's study—published in 1967—found that the messages were delivered by "chains" comprising anywhere between two and ten intermediaries, with the average number being five intermediaries.²³

Milgram's experiment sprung out of a desire to better understand how people were connected. Most importantly, Milligram's study proved that

¹⁷ Korte & Stanley Milgram, *supra* note 16.

¹⁸ Jeffrey Travers & Stanley Milgram, *The Small World Problem*, 1 PSYCHOL. TODAY 61, 62 (1967).

¹⁹ *Id.* at 64.

²⁰ *Id.* at 65.

²¹ *Id.* at 60–67.

²² *Id.*

²³ *Id.* at 65.

the world is a much smaller social network of interlinked individuals than we ever imagined and provided the ultimate benchmark against which our interconnectedness these days can be measured.

Indeed, Facebook decided to run its own experiment based on Milligram's idea to find whether the median number of five intermediaries that Milgram had found still stood today. While Karinthy had speculated, and Milgram proved, that a chain of just five individuals between people can link any two on the planet, Facebook's studies across years suggest that the world is growing smaller and smaller while we become more and more interconnected.²⁴ In 2011, when Facebook had just over one tenth of the world's population as active users, they found that there were 3.74 degrees of separation.²⁵ In 2016, with Facebook's active users increasing to 1.5 billion—roughly one quarter of the world's population—the research suggested that there are 3.57 degrees of separation. In other words, if you pick any two Facebook users, each is connected to every other person by an average of three and a half other people.²⁶

Today, social media platforms have taken it upon themselves to capitalize on pre-existing human networks but also boost peoples' interconnectedness. With technological advances making the relevance of networks in our daily lives and the world ever more evident, the significance of networks cannot be overstated.

B. *The Different Lens of Networks*

The term “network” is used almost open-endedly to refer to several structural formations across disciplines. In the widely-cited definition of Joel M. Podolny and Karen L. Page, a network is “any collection of actors ($n \geq 2$) that pursue repeated, enduring exchange of relations with one another and, at the same time, lack a legitimate organizational authority to arbitrate and resolve disputes that may arise during the exchange.”²⁷ In scholarship, networks are usually juxtaposed with markets and hierarchies, as alternative structures.²⁸ Fields as diverse as social sciences, biology, engineering, computer science, and organizational studies, have identified and recognized the importance of networks and their role in the development of a “systems theory” in each respective discipline.²⁹

²⁴ Smriti Bhagat et al., *Three and a Half Degrees of Separation*, FACEBOOK RES. (Feb. 4, 2016), <https://research.fb.com/blog/2016/02/three-and-a-half-degrees-of-separation/>.

²⁵ *Facebook Users Average 3.74 Degrees of Separation*, BBC NEWS (Nov. 23, 2011), <https://www.bbc.com/news/technology-15844230>.

²⁶ Bhagat, *supra* note 24.

²⁷ Joel M. Podolny & Karen L. Page, *Network Forms of Organization*, 24 ANN. REV. SOC. 57, 59 (1998).

²⁸ MILES KAHLER, NETWORKED POLITICS: AGENCY, POWER, AND GOVERNANCE 2 (2015).

²⁹ See, e.g., Michael G.H. Bell, *A Game Theory Approach to Measuring the*

In terms of structure, the core building blocks of a network are its nodes and edges.³⁰ A node is usually an actor and edges represent the relationships among multiple nodes. In other words, a network is a set of interconnected nodes. What constitutes a node and an edge depends on the context and application of a network. These can be people and the relationships among them. They can be countries and their global trade relationships. They can be poppy fields and clandestine drug trafficking groups. They can be stock exchange markets and service centers in global financial flows. They can be Hollywood actors and the movies they star in.

The term “network” has been applied liberally due to the unique nature of each network. But networks traditionally share a set of minimum common characteristics such as participation, process, enforcement, and institutionalization.³¹ The main construction of the term “network” across fields reflects a group of nonhierarchical but heavily interdependent entities.³² These entities often exhibit high levels of informality in collaboration while demonstrating increased rule making functions.³³ This very nature of networks often offers a fast and flexible alternative to traditional organization and rulemaking that can provide more expedient and effective responses. This is one of the most important characteristics for the role of networks in international law making that will be the focus of our analysis of networks in the international system.

But before jumping to the legal and international system there is a more elementary set of questions that linger: why do networks emerge and what warrants their analysis? Networks, as structures, fall in the middle between hierarchies and markets. On the one hand, hierarchies represent

Performance Reliability of Transport Networks, 34 *TRANSP. RES. PART B: METHODOLOGICAL* 533, 533 (2000); Jennifer A. Dunne et al., *Food-Web Structure and Network Theory: The Role of Connectance and Size*, 99 *PROC. NAT'L ACAD. SCI.* 12917, 12917 (2002); Alireza Khotanzad et al., *ANNSTLF-Artificial Neural Network Short-Term Electric Load Forecasting System Generation Three*, 13 *IEEE TRANSACTIONS ON POWER SYS.* 1413, 1413 (1997); Michael J. Lovaglia et al., *Negotiated Exchanges in Social Networks*, 74 *SOC. FORCES* 123, 123 (1995); Ron Milo et al., *Network Motifs: Simple Building Blocks of Complex Networks*, 298 *SCI.* 824, 824–25 (2002); R. Bruce Money, *International Multilateral Negotiations and Social Networks*, 29 *J. INT'L BUS. STUD.* 695, 695 (1998).

³⁰ David Lazer, *Networks and Politics: The Case of Human Rights*, in *UNDERSTANDING SOCIAL ACTION, PROMOTING HUMAN RIGHTS* 246 (Ryan Goodman et al. eds., 2012).

³¹ Abraham Newman & David T. Zaring, *Regulatory Networks: Power, Legitimacy, and Compliance*, in *INTERDISCIPLINARY PERSPECTIVES ON INTERNATIONAL LAW AND INTERNATIONAL RELATIONS: THE STATE OF THE ART* 244, 245 (Jeffrey Dunoff & Mark Pollack eds., 2013).

³² Lazer, *supra* note 30, at 245.

³³ *Id.*; Yane Svetiev, *The Limits of Informal International Law*, in *INFORMAL INTERNATIONAL LAWMAKING* 271, 271 (Joost Pauwelyn et al. eds., 2012).

an organizational model that is based on rule-driven design and direction.³⁴ Markets, on the other hand, are largely decentralized and achieve coordination by using intuitive methods such as signaling.³⁵ Networks are neither as rigid as hierarchies nor as fluid as markets. Instead, they contain more informal linkages than the heavily bureaucratic hierarchies but have a more sophisticated organizational coordination beyond the mere signaling mechanisms of markets. They tend to emerge where markets and hierarchies are not present or are unable to provide a necessary or optimal organizational platform for action.³⁶

There is not one clear explanation as to why networks emerge. Optimistic functionalism often answers the question “why do networks emerge?” by justifying the end result of delivering a beneficial outcome.³⁷ Yet organizational structures may also emerge and persist through time due to convenience, habit, or inertia, without necessarily carrying a functional advantage over others.³⁸ While hierarchies tend to be too rigid and value rank over flexibility and agility, markets are too opportunistic and short-termed to provide actors with sufficient and well-informed results.³⁹ A hybrid organizational form like the network falls into neither of these traps: it carries some of the flexibility of markets and combines it with the more principled and less opportunistic reciprocal approach of hierarchies. Networks are also capable of having their own distributions of power, hierarchy, and governance.⁴⁰ They do not always function as flat environments of link distribution, but rather as “scale-free” entities with actors that may assume more or less dominant positions based on their centrality within the network.⁴¹ Networks are thus usually quicker to react than hierarchies and more effective to respond to complexity than markets.⁴² These three organizational models may also exist in symbiosis, such as networks we encounter within hierarchical environments or

³⁴ GRAHAME THOMPSON, *BETWEEN HIERARCHIES AND MARKETS: THE LOGIC AND LIMITS OF NETWORK FORMS OF ORGANIZATION* 22 (2003)

³⁵ *Id.* at 24.

³⁶ ROBERT J. HOLTON, *GLOBAL NETWORKS* 32 (2007).

³⁷ See Timur Kuran, *The Tenacious Past: Theories of Personal and Collective Conservatism*, 10 J. ECON. BEHAV. & ORG. 143, 144 (1988).

³⁸ HOLTON, *supra* note 36, at 33.

³⁹ HOLTON, *supra* note 36, at 35.

⁴⁰ CHARLI R. CARPENTER, “LOST” CAUSES: AGENDA VETTING IN GLOBAL ISSUE NETWORKS AND THE SHAPING OF HUMAN SECURITY 20 (2014).

⁴¹ The term “scale-free” refers to the following property. Consider degree d and some other degree cd , for some scalar c and a parameter y . Their relative frequencies are $d^{-y}/(cd^{-y})$ or c^y . Now consider some other degree d' and another degree cd' . Their relative frequencies are also c^y . Thus, regardless of how we have rescaled things, relative frequencies depend only on relative sizes and not on the absolute scale.

⁴² HOLTON, *supra* note 36, at 35.

markets.⁴³ But, at all times, configuring the relationships among the nodes of networks helps to map how these structures function and to measure their various effects.⁴⁴

There are many systems of interest to researchers that are structured as networks, from the Internet and World Wide Web, to social interactions, human societies, chemical particles, products distribution, military alliances, and interactions among judges and courts. Certain mathematical and statistical tools can reduce these systems from abstract structures to sets of simplified representations of connections and patterns. This method has its limitations but offers important advantages, especially when combined with additional or mixed research methods. Getting accustomed to seeing the world through networks requires a conceptual and epistemological shift that some disciplines have embraced more than others. Surveying the way the introduction of a networks perspective has affected the closest discipline to international law, that of international relations, will help us better implement this shift in the way we perceive the international legal system, and thereby come to understand it better.

C. Networks in the International Legal System

To explore the ways in which actors connect, it is critical to establish an analytical framework. One of the primary purposes of international law has been to facilitate solutions in different sets of problems caused by the anarchical international system and its central governance vacuum.⁴⁵ The range of international problems that could trigger international normative development is nearly infinite. But under such problem-driven approach, one can identify certain types of networks that preexist or emerge to address a certain type of problem through normative development such as treaty, customary international law, or even soft law.

These networks represent any empirically verifiable and demonstrable group of actors and their interactions throughout certain law making processes that lead to international normative development.⁴⁶ These can include but are not limited to states, international organizations, non-governmental organizations, international or domestic courts and tribunals, and even corporations or individuals. There is no established line of demarcation separating the actors that may be involved in the networks and those that may not for the purposes of research analysis. The deciding factor for these actors is simply their connection to other actors involved in

⁴³ HOLTON, *supra* note 36, at 37.

⁴⁴ Lazer, *supra* note 30, at 245.

⁴⁵ See Irena Omelaniuk, *Global Migration Institutions and Processes*, in FOUNDATIONS OF INTERNATIONAL MIGRATION LAW 336 (Brian Opeskin et al. eds., 2012).

⁴⁶ See *supra* notes 20–27.

international legislative processes. The goal then is to map, through quantitative means, which actors contribute what to the legislative network, or to the process of normative development, and why.

Networks were introduced in politics and international relations in the 1970s in an effort to unpack traditional concepts of what constitutes the “state.”⁴⁷ International political economy began to focus its analytical lens on sub-state interactions and their policy outcomes as a result of the forces of growing economic and political interdependence.⁴⁸ Robert Keohane and Joseph Nye introduced and defined the concept of “transgovernmental relations” as relations between officials “that are not controlled or closely guided by the policies of the cabinets or chief executives of those governments.”⁴⁹ The 1980s decline of the US hegemony and rise of new powers engendered further theories that focused on the interactions of different sets of actors beyond unitary states within the international system.⁵⁰ In the 1990s, Peter Haas promulgated the idea of an “epistemic community” operating as “a network of professionals with recognized expertise and competence in a particular domain and an authoritative claim to policy-relevant knowledge within that domain or issue-area.”⁵¹ Anne-Marie Slaughter advanced the idea of a “new world order” that is increasingly shaped by networks of lower-level governmental officials with cross-border policy agendas.⁵² These officials’ formal or informal interactions with their foreign counterparts and without direct central authority involvement gives them a special role in cross-border regulation.⁵³

These developments have led to a conceptual and epistemological shift from states as sole unitary actors acting within an international system that appeared to have space only for them, to their “disaggregation” into their many individual components.⁵⁴ Some early scholars in international

⁴⁷ Newman & Zaring, *supra* note 31, at 248; *see also* ROBERT O. KEOHANE & JOSEPH S. NYE, *POWER AND INTERDEPENDENCE* 8 (1977); THOMAS RISSE-KAPPEN, *BRINGING TRANSNATIONAL RELATIONS BACK IN: NON-STATE ACTORS, DOMESTIC STRUCTURES AND INTERNATIONAL INSTITUTIONS* 15 (1995).

⁴⁸ Kal Rausiala, *The Rise of Transnational Networks Conference November 7, 2008 Transnational Networks: Past and Present*, 43 INT’L L. 205, 206 (2009).

⁴⁹ KEOHANE & NYE, *supra* note 47, at 42.

⁵⁰ Anne-Marie Slaughter & David Zaring, *Networking Goes International: An Update*, 2 ANN. REV. L. & SOC. SCI. 211, 214 (2006).

⁵¹ Peter M. Haas, *Introduction: Epistemic Communities and International Policy Coordination*, 46 INT’L ORG. 1, 3 (1992).

⁵² Anne-Marie Slaughter, *Sovereignty and Power in a Networked World Order*, 40 STAN. J. INT’L L. 40, 283 (2004).

⁵³ ANNE-MARIE SLAUGHTER, *A NEW WORLD ORDER* 62 (2009).

⁵⁴ *See* KEOHANE & NYE, *supra* note 47, at 8; RISSE-KAPPEN, *supra* note 47, at 15; Newman & Zaring, *supra* note 31, at 248; Slaughter, *supra* note 52, at 283.

law had also emphasized the importance of tracing the rise, position, and relationships of those components, some of which, in lieu of a better term,⁵⁵ became known as “non-state actors.”⁵⁶ Legal process theorists first introduced the idea of a web of state and non-state actors in the 1950s and 1960s without developing a comprehensive theory on their role and effect in international law.⁵⁷ This was likely due to strict conceptions of “legal personality” that barred such informal structures from having a seat at the table of the exclusive club of state actors participating in international law and international relations.⁵⁸ At the same time, cross-border disputes presented issues for which traditional international law tools were not equipped to handle and caused some areas of international law to witness increased network proliferation.⁵⁹ Fields such as environmental law and international financial regulation were increasingly exposed to challenges that required a new type of international coordination addressing the practical necessities of international interdependence.⁶⁰ These ventures, however, lacked a more comprehensive conceptual framework of analysis, or were simply viewed as practical instead of binding legislative coordinative efforts in response to systemic deficiencies.⁶¹ The networks scholarship that emerged in these fields mostly assumed the more limited task of documenting the evolution of regulatory networks and their effect on actors’ structures and power distributions.⁶²

In sum, the field of international relations has been preoccupied with questions relating to the nature of these networks of state and non-state actors,⁶³ their operations,⁶⁴ and their effect on power distributions,⁶⁵ policy

⁵⁵ As Philip Alston suggested, international law suffers from the “not-a-cat-syndrome” in its reference to “non-state actors” as “non-state.” See Philip Alston, *The ‘Not-a-Cat’ Syndrome: Can the International Human Rights Regime Accommodate Non-State Actors?*, in NON-STATE ACTORS AND HUMAN RIGHTS 3, 3 (Philip Alston ed., 2005). This marginalizes the scope of research and reinforces “the assumption that the state is the only central actor.” *Id.*

⁵⁶ See generally PHILIP CARYL JESSUP, *TRANSNATIONAL LAW* (1956) (discussing Philip Jessup as having introduced international lawyers to “transnational law” in 1958 and defining it as “all law which regulates actions or events that transcend national frontiers. Both public and private International Law are included, as are other rules which do not wholly fit into such standard categories.”); see also HENRY J. STEINER & DETLEV F. VAGTS, *TRANSNATIONAL LEGAL PROBLEMS* (1976) (describing how Henry Steiner and Detlev Vagts later translated this concept into a case-book, collecting materials designed to bridge the gap between the domestic and international legal world in HENRY J. STEINER ET AL., *TRANSNATIONAL LEGAL PROBLEMS: MATERIALS AND TEXT* (1986)).

⁵⁷ Slaughter & Zaring, *supra* note 50, at 213.

⁵⁸ *Id.*

⁵⁹ Slaughter & Zaring, *supra* note 50, at 215.

⁶⁰ *Id.*; Raustiala, *supra* note 48, at 206.

⁶¹ Slaughter & Zaring, *supra* note 50, at 214.

⁶² Slaughter & Zaring, *supra* note 50, at 211–12.

⁶³ Kal Raustiala, *The Architecture of International Cooperation: Transgovernmental*

convergence,⁶⁶ and agenda setting.⁶⁷ International legal scholarship has largely shied away from the complications that non-state actors and the networks they tap into present to traditionally rigid areas such as that of international law making.⁶⁸ The study of non-state actors and the networks they belong to in international law has been limited to identifying the relationships among non-state actors and states under the assumption that the former lack any constitutive legislative power. This establishes a gap between the policy nature and effect of non-state actors and networks, on the one hand, and their potential legislative effect, on the other.

But an extraordinary range of international law norms is created today by actors and through processes that do not fit easily into the traditional state actors of international law.⁶⁹ Although states remain the primary makers of international law, many other participants including international organizations, courts, as well as influential entities in international law advocacy, such as non-governmental organizations (NGOs), and even individuals, are also crucial to the development of international legal norms.⁷⁰ One of the problems in contemporary international law is the disconnect between the way international law is actually made with the participation of these various actors, on the one hand, and the extensive theoretical focus on states and their effect on the four classic international law “sources,” on the other. While scholars are not blind to this gap, there is, of yet, no formal model integrating these actors into existing frameworks “that are theoretically and legally structured only for states.”⁷¹ The next part of this Article aims to narrow this gap by providing a framework of analysis for the contributions of these actors and structures to the making of international law.

Configuring the relationships among the actors, or, as we will be calling them, nodes of these networks will help us understand how these

Networks and the Future of International Law, 43 VA. J. INT’L L. 1, 3 (2002); see also Newman & Zaring, *supra* note 31, at 253.

⁶⁴ Slaughter, *supra* note 52, at 290.

⁶⁵ *Id.*

⁶⁶ Raustiala, *supra* note 48, at 209.

⁶⁷ CARPENTER, *supra* note 40, at 20.

⁶⁸ For a notable exception to this proposition see Mark A. Pollack & Gregory C. Shaffer, *The Interaction of Formal and Informal International Lawmaking*, in *INFORMAL INTERNATIONAL LAWMAKING* 251 (Joost Pauwelyn ed., 2012).

⁶⁹ See generally Duncan B. Hollis, *Why State Consent Still Matters—Non-State Actors, Treaties, and the Changing Sources of International Law*, 23 BERKELEY J. INT’L L. 137 (2005).

⁷⁰ See generally ALAN BOYLE & CHRISTINE CHINKIN, *THE MAKING OF INTERNATIONAL LAW* (2007).

⁷¹ ANNE-MARIE SLAUGHTER, *THE CHESSBOARD AND THE WEB: STRATEGIES OF CONNECTION IN A NETWORKED WORLD* 22–23 (2017).

networks are involved in international law making, and measure their actual legislative effect.⁷² Many of the networks that have been involved in international norm creation are not networks comprised only of states or networks comprised only of non-state actors. Instead, they are structures with their own types of relationships and hierarchies in which different types of actors participate, including states and non-state actors. The evaluation of the actor distributions and relationships within these networks will elucidate the ways that normative prescriptions are adopted, diffused, and cascade, as well as clarify how these emerging norms find their way to the table, proliferate, and become part of international law.⁷³ Seeing international relations and international law through networks will provide international lawyers and international policy-makers with a descriptive tool that translates and maps the elusive process of international law making.

But why would international actors engage in such a paradigm shift that arguably reduces the role of states in international relations and law? Considering states have traditionally held certain monopolies of power, such as the monopoly of making international law, it seems almost counterintuitive that they would choose to engage in relationships with non-state actors through networks instead of following traditional paths of rule-making. Non-state actors are becoming increasingly influential, due, in large part, to the inadequacy of the strict hierarchical state-centered international system to effectively address emerging international law problems, such as human rights violations, environmental issues, and international financial crises.⁷⁴ Yet states remain the main actor that can officially legislate in the international terrain, and exercise legitimate influence and coercion over private actors or organizations.⁷⁵ This conundrum has led many non-state actors that were at first critical of the state system to engage more constructively with it. This process has yielded the formation of these networks of state and non-state actors.⁷⁶

Non-state actors also realize that they do not have enough authority to develop legally-binding norms. They must promote these norms through transnational campaigns that inform and persuade other actors of their

⁷² See Lazer, *supra* note 30, at 245.

⁷³ For advocacy agenda setting under a similar light see generally CARPENTER, *supra* note 40.

⁷⁴ See generally Angela M. Banks, *The Growing Impact of Non-State Actors on the International and European Legal Systems*, 5 INTERNATIONAL LAW FORUM DU DROIT INTERNATIONAL 293 (2003).

⁷⁵ JAMES CRAWFORD, THE INTERNATIONAL LAW COMMISSION'S ARTICLES ON STATE RESPONSIBILITY: INTRODUCTION, TEXT AND COMMENTARIES 77-121 (2002).

⁷⁶ Kal Raustiala, *States, NGOs, and International Environmental Institutions*, 41 INT'L STUD. Q. 719, 736 (1997).

cause.⁷⁷ These transnational actors are a necessary but not sufficient condition for the diffusion and adoption of emerging norms. Non-state actors eventually need to gain the support of states, tap into their processes, and inform and influence their beliefs and practice. Sikkink argues that non-state actors do so through their only available tool, the power of persuasion.⁷⁸ She bases this argument on what she believes is the inability of these groups to “coerce” agreement with a norm. Instead, they can only rely on discourse, information, and often-dramatized symbolic activity.⁷⁹ This rings true in a hierarchical international system, where the state is on the top of the pyramid. But in a world of networks that involve states as well as non-state actors, the linkages connecting them, and their individual positions, are of the essence. In this more fluid environment, state and non-state actors enjoy different structural positions, levels of power and influence, and carry diverse sets of tools than in the hierarchical system. As a node in the network, non-state actors, for instance, may position themselves in ways that confer certain aspects of structural power and influence without having this power as a matter of law. In analyzing these relationships with the toolset of network theory, we will find that this new structural environment offers a means to overcome the inflexibility of hierarchies, particularly in new international law challenges, without running the risk of the potential haphazard effect of markets.

Slaughter argues that the continued interaction of sub-state actors within transgovernmental networks will advance international cooperation and reduce international conflict.⁸⁰ She also posits that a combination of perspectives that includes seeing states as unitary actors and as sites of different networks offers a way to see the world “in stereo” without either perspective excluding the other.⁸¹ This, for Slaughter, will facilitate the

⁷⁷ See, e.g., MARGARET E. KECK & KATHRYN SIKKINK, *ACTIVISTS BEYOND BORDERS: ADVOCACY NETWORKS IN INTERNATIONAL POLITICS* 1–3 (1998) (discussing the non-state actors’ role in the anti-slavery campaign, the campaign for women’s suffrage, campaigns for international human rights and the elimination of violence against women); Audie Klotz, *Norms Reconstituting Interests: Global Racial Equality and U.S. Sanctions Against South Africa*, 49 INT’L ORG. 451, 451 (1995) (discussing the development of international racial norms in favor of an international anti-apartheid campaign against South Africa); Richard Price, *Reversing the Gun Sights: Transnational Civil Society Targets Land Mines*, 52 INT’L ORG. 613, 613 (1998) (discussing non-state actors’ role in recent campaigns against the use of landmines); Thomas Risse-Kappen, *Ideas Do Not Float Freely: Transnational Coalitions, Domestic Structures, and the End of the Cold War*, 48 INT’L ORG. 185, 187 (1994) (discussing the role of transnational networks of “epistemic communities” in influencing policy).

⁷⁸ Kathryn Sikkink, *Transnational Politics, International Relations Theory, and Human Rights*, 31 PS: POL. SCI. & POL. 517, 519 (1998).

⁷⁹ *Id.*

⁸⁰ SLAUGHTER, *supra* note 53, at 169–70.

⁸¹ SLAUGHTER, *supra* note 71, at 66–69.

development of a set of tools to address the hardest foreign policy problems by making use of resilience, task and scale based networks.⁸² Raustiala considers certain international networks as a tool states can use to more effectively meet international challenges.⁸³ Zaring maintains that networks of regulators can more efficiently respond to globalization challenges and contribute to the rule of law by increasingly incorporating law-like features.⁸⁴ Dunoff sees the growth of international networks as an opportunity for wider participation of non-state actors and particularly the civil society in international law making.⁸⁵ Even though these arguments are intuitively compelling, they lack the descriptive analysis that serves as a blueprint of exactly how these networks operate and what they produce. A quantitative method of analysis can assess not only whether these propositions are accurate, but also decode the intricacies of these new social and organizational structures, and facilitate even more sophisticated qualitative findings.

For this reason, it is salient to identify the relevant actors who participate in international legal processes, their various degrees of participation, and their capabilities.⁸⁶ This necessitates a descriptive approach that has been largely absent from the scholarship or has been unsystematic. The question of who participates in these networks and on what grounds is of particular importance to understanding these processes and evaluating how they fit within the existing frameworks of international law development.⁸⁷ Descriptive quantitative work can clarify network dynamics such as levels of socialization within a network or networks, diffusion of norms based on the nature and strength of actors or ties, the importance of certain individual actors, and the formation of actor identities.⁸⁸

⁸² SLAUGHTER, *supra* note 71, at 77.

⁸³ Raustiala, *supra* note 63, at 17–19.

⁸⁴ David Zaring, *International Law by Other Means: The Twilight Existence of International Financial Regulatory Organizations*, 33 TEX. INT'L L. J. 281, 323–25 (1998).

⁸⁵ See Jeffrey L. Dunoff, *Public Participation in the Trade Regime: Of Litigation, Frustration, Agitation and Legitimation*, 56 RUTGERS L. REV. 961, 964 (2004).

⁸⁶ Andrea Bianchi, *The Fight for Inclusion: Non-State Actors and International Law*, in FROM BILATERALISM TO COMMUNITY INTEREST: ESSAYS IN HONOUR OF JUDGE BRUNA SIMMA 39, 48 (Ulrich Fasenrath et al. eds., 2011).

⁸⁷ *Id.* at 48–49.

⁸⁸ Emily M. Hafner-Burton, Miles Kaahler, & Alexander H. Montgomery, *Network Analysis for International Relations*, 63 INT'L ORG. 559, 569 (2009).

D. Potential Objections Against Networks

Examining networks of actors on the basis of their involvement in international legislative processes carries an obvious endemic objection, an elephant in the room. This elephant, though capable of manifesting in various forms, goes by the name “legal personality.” While actors such as non-governmental organizations, international or domestic courts and tribunals, and even individuals may participate in and interact throughout certain international law making processes,⁸⁹ they do not, as a matter of law, have the necessary legal personality to create international law.⁹⁰ And without legal personality, one may be tempted to call this a futile exercise. If these non-state actors aren’t capable of making international law because they lack formal recognition as international law makers, why should they even form part of the analysis? In a legal system where legislative process and action were fully understood, articulated, and definite, this objection would be credible. The current international law terrain, however, far from offers unambiguous answers concerning its normative development.

What happens if, for the sake of the argument, the proposed analysis indicates that non-state actors have equal, if not more, power in putting forward new or amended international law norms than states? Notice the circularity problem: if we are to continue to operate under the presumption that actors that are currently lacking legal personality but are actively participating in international legislative processes don’t matter for international law making, then we may never trace and understand their *de facto* role in them. Yet such increased appreciation may assist in clearing out the existing clouds surrounding the development of international law and perhaps even clarify the source of our haze. The goal of this Article is not to make any normative claim over the nature and legal position of non-state actors. Instead, it carves out a far more limited and perhaps less ambitious task. That is to offer a framework with which to map which actors contribute what to the process of international normative development and how. For these purposes, certain objections become less salient or “objectionable.”

⁸⁹ CRAWFORD, *supra* note 75, at 30; HOLLIS, *supra* note 69, at 137.

⁹⁰ See *Reparation for Injuries Suffered in Service of United Nations*, Advisory Opinion, 1949 I.C.J. 174, 178 (Apr. 11). A development that expanded notions of legal personality in current mainstream approaches to international law is the case of International Organizations that enjoy legal personality in relation to the states that created or interact with them. *Id.* Despite this relative exception of International Organizations to the general legal personality the debate still stands often in relation to other non-state actors but also International Organizations.

1. The “Subjects” Doctrine

International legal doctrine is preoccupied with identifying the ways of determining who has the legal personality and, therefore, authority to create international law – rendered as “subjects” of international law – but also, the legitimacy to participate in international legislative processes with normative effect.⁹¹ Meanwhile, developments in international relations do not always render the social structure of international law and its “subjects” as mutually constitutive.”⁹² The emergence of different actors in the international community with a “variety of participants, making claims across state lines” has blurred the strict line of demarcation between “subjects” and “non-subjects” of international law.⁹³ It is true that when “one tries to define the precise extent of the legal personality which non-state actors have acquired, one enters into a very controversial area of the law. The problem of including new actors in the legal system is reflected in the very concept of legal personality.”⁹⁴ Challenges to traditional conceptions of legal personality in international law not only question the role of the state, but also the subject versus non-subject binary. It is precisely the growing number of non-state actors that take part in international law making processes, originally reserved for states, that lead us to ask whether the notion of legal personality has changed, or whether we witness different levels and forms of legal personality that diverge from the “original” one that attached only to states regarding international law making.⁹⁵

Most objections and skepticism on the inclining role of non-state actors in international law arise from this emphasis on legal personality. Few attempts have been made to establish a new working framework separate from the traditional “subjects doctrine” that could incorporate the increased influence and participation of non-state actors in international law making. Some argue that *de facto* influential actors in international law making – be it state or non-state actors – have a normative responsibility,⁹⁶ and a presumed duty to conform to international obligations attached to “the promotion of community interests such as the

⁹¹ Bianchi, *supra* note 86, at 42.

⁹² Bianchi, *supra* note 86, at 41.

⁹³ ROSALYN HIGGINS, PROBLEMS AND PROCESS: INTERNATIONAL LAW AND HOW WE USE IT 150 (1994).

⁹⁴ ALEXANDER ORAKHELASHVILI, AKEHURST’S MODERN INTRODUCTION TO INTERNATIONAL LAW 91 (Alexander Orakhelashvili ed., 8th ed. 2018).

⁹⁵ See Math Noortmann, *Transnational Law: Philip Jessup’s Legacy and Beyond*, in NON-STATE ACTOR IN INTERNATIONAL LAW 57, 63 (Noortmann et al. eds., 2001).

⁹⁶ Karsten Nowrot, *New Approaches to the International Legal Personality of Multinational Corporations: Towards a Rebuttable Presumption of Normative Responsibilities*, 9 J. GLOB. LEGAL STUD. 1, 3 (1993).

protection of human rights, the environment, and core labor and social standards.”⁹⁷ Others propose a reevaluation of the structure of international law and departure from the formalistic doctrines of subjects and legal personality altogether: “The new actors in our globalizing world might more easily be molded into the system of international law if we try to conceive of them as factors and forces of a broader constitutional order.”⁹⁸ In this constitutionalist perspective, states no longer have a law making monopoly but instead are participants in a larger spectrum of actors involved. A third approach attempts to revise the notion of international legal personality based on cosmopolitan and hermeneutic theories.⁹⁹ It argues that individuals possess “a natural right to political participation [and] the right to have rights, [which] includes the right to live in a world governed by *just* institutions[.]”¹⁰⁰ It posits that the notions of “subjects” and “legal personality” in international law are changing and non-state actors have a “natural right to political participation”¹⁰¹ or “at least a legitimate expectation” to a “general right to participate in international legal discourse.”¹⁰²

Notwithstanding the growing recognition of non-state actors, legal doctrine still considers international law making as an essential prerogative of states, and states as the sole “subjects” of international law for its purposes.¹⁰³ The gap between legal formalism and the normative activism of non-state actors including their growing international privileges and expectations remains and increases.¹⁰⁴ According to Charlesworth and Chinkin, the reason is that these actors “are often considered part of the

⁹⁷ Bianchi, *supra* note 86, at 43.

⁹⁸ Daniel Thürer, *The Emergence of Non-Governmental Organizations and Transnational Enterprises in International Law and the Changing Role of the State*, in NON-STATE ACTORS AS NEW SUBJECTS OF INTERNATIONAL LAW 37, 74 (Rainer Hofmann & Nils Geissler eds., 1999).

⁹⁹ JANNE ELISABETH NIJMAN, THE CONCEPT OF INTERNATIONAL LEGAL PERSONALITY: AN INQUIRY INTO THE HISTORY AND THEORY OF INTERNATIONAL LAW 472–73 (2004).

¹⁰⁰ *Id.* at 472.

¹⁰¹ *Id.* at 473; *see also* Steve Charnovitz, *The Emergence of Democratic Participation in Global Governance*, 10 IND. J. GLOB. LEGAL STUD. 45 (2003).

¹⁰² ANNA-KARIN LINDBLOM, NON-GOVERNMENTAL ORGANIZATION IN INTERNATIONAL LAW 526 (2005).

¹⁰³ INTERNATIONAL LAW ASSOCIATION, FIRST REPORT OF THE COMMITTEE: NON-STATE ACTORS IN INTERNATIONAL LAW: AIMS, APPROACH AND SCOPE OF PROJECT AND LEGAL ISSUES 655 (2010); *see, for an anthology of international legal personality*, Fleur E. Johns, *International Legal Personality* (Sydney Law Sch., Res. Paper No. 09/113, 2009), https://papers.ssrn.com/sol3/papers.cfm?abstract_id=1487383.

¹⁰³ Noortmann, *supra* note 95, at 71.

¹⁰³ HILARY CHARLESWORTH & CHRISTINE CHINKIN, THE BOUNDARIES OF INTERNATIONAL LAW: A FEMINIST ANALYSIS 31 (2000).

¹⁰⁴ Noortmann, *supra* note 95, at 71.

'private' within the international legal arenas and part of the 'public' in the domestic fora."¹⁰⁵ But they equally acknowledge that the "location [of non-state actors] at the intersection between public and private spheres illustrates the changing boundaries of International Law."¹⁰⁶ This tension between the existing largely formalistic legal framework and the growing factual reality has been further complicated by questions of legitimacy, accountability, and a lack of democratic deficit of non-state actors.¹⁰⁷ While these objections are not necessarily without merit, they creep in due to lack of a more systematic representation and understanding of international law making that incorporates these actors and traces their effect. I propose instead that seeing international law making processes through the networks that facilitate them will allow us to map the actors involved, trace their effect, understand their synergies, and facilitate a framework that is a measured reflection of international law making today.

2. Questions of Legitimacy

In addition to the changing role of state and non-state actors in international law, there are also theoretical and methodological concerns regarding any inclusion of non-state actors in international law making. These concerns involve: (1) whether the state is the only legitimate international law actor; (2) if not, whether non-state actors possess the sufficient elements to be considered legitimate; and (3) whether they can be held accountable for their practice.¹⁰⁸ Even though the debates on the nature and meaning of the term "legitimacy" are a long and arduous matter, we generally understand legitimacy as either a social concept or a normative concept. As a social matter, to be legitimate means to be accepted and recognized. As a normative matter, it means to be worthy of being recognized.¹⁰⁹ The two concepts are analytically and conceptually independent. For instance, the adoption of a standard such as the exclusion of women from voting may be socially legitimate if all members of a society recognize it as such. It would be normatively legitimate only if it conforms with currently accepted civil and human rights standards.

There are two main ways of assessing normative legitimacy. According to the more utilitarian "outcome legitimacy," the more effective an actor or a circumstance is at delivering outcomes that are satisfactory to

¹⁰⁵ CHARLESWORTH & CHINKIN, *supra* note 103.

¹⁰⁶ *Id.*

¹⁰⁷ Pollack & Shaffer, *supra* note 68, at 243.

¹⁰⁸ INTERNATIONAL LAW ASSOCIATION, *supra* note 103, at 645.

¹⁰⁹ Anne Peters et al., *Towards Non-State Actors as Effective, Legitimate and Accountable Standard Setters*, in NON-STATE ACTORS AS STANDARD SETTERS 492, 511 (Anne Peters et al. eds., 2009).

the greater amount of people, the more legitimate they are.¹¹⁰ On the other hand, “process legitimacy” attaches itself to the means through which these outcomes are achieved irrespective of their end quality; in other words whether the processes are fair, transparent, and accountable.¹¹¹ Typically, non-state actors receive attacks on both these legitimacy counts. Non-state actors exercising governance functions often trigger questions of transparency or accessibility when juxtaposed to elected government.¹¹² The relative flexibility and informality of their operations suggests, for some, that they do not fall under the same constraints imposed on more “formal” types of governance, including standards and procedures.¹¹³

Is there merit to these attacks? I think the answer is yes, in part. But we may resolve these legitimacy issues without abandoning attention on the undoubted involvement of non-state actors in international law and international law making. Many legitimacy objections over non-state actor participation are based on traditional, vertical, state-centric views of the international system. States are able to control the extent and quality of non-state actor participation in their constituencies, expand or restrict it at will, while exercising and maintaining their full traditional sovereignty.¹¹⁴ The limited role carved out for non-state actors may well stem from transposing a legitimacy model that belongs to hierarchical legal and political structures into a more mixed and increasingly horizontal international landscape. Such an approach effectively attempts to draw an analogy between systems that, at least for purposes of legitimacy, are fundamentally distinct.

But even if we were to accept, for the sake of the argument, that, currently, non-state actors are treated under the correct legitimacy standard, the question remains: do we hold non-state actors to the same legitimacy requirements to which we hold the rest of the international system? Andrew Moravcisk has argued that it is important not to impose more rigid legitimacy requirements on non-state actors than we do on states.¹¹⁵ While non-state actors are often attacked for legitimacy gaps because they are compared to idealized democratic systems and formalistic notions of

¹¹⁰ Anne-Marie Slaughter, *The Power and Legitimacy of Government Networks*, in SOCIETY FOR INTERNATIONAL DIALOGUE, THE PARTNERSHIP PRINCIPLE, NEW FORMS OF GOVERNANCE IN THE 21ST CENTURY 7 (2004).

¹¹¹ *Id.*

¹¹² *Id.*

¹¹³ *Id.*

¹¹⁴ See Asher Alkoby, *Non-State Actors and the Legitimacy of International Environmental Law*, 3 NON-STATE ACTORS INT'L L. 23, 70, 88–89 (2003).

¹¹⁵ Andrew Moravcisk, *Is There a “Democratic Deficit” in World Politics? A Framework for Analysis*, 39 GOV'T & OPPOSITION 336, 337 (2004).

legitimacy, we do not often hold states to such standards in practice.¹¹⁶ Where states do not live up to their expected legitimacy standards, holding non-state actors against idealized forms of state governance instead of “real world” standards may seem, in itself, rather “illegitimate.”

To examine non-state actors’ outcome legitimacy, it is helpful to ask why non-state actors get involved in international relations in the first place? In established systems, new actors emerge when there is need for political authority and private regulation, and an empty institutional space to fill.¹¹⁷ In such “institutional voids,” the roles, expectations, and objectives of agencies are unclear, and private action comes in to resolve the need for regulation, and to increase clarity and transparency.¹¹⁸ These institutional voids may be intended or unintended.¹¹⁹ States may deliberately cease certain fields and leave it to private actors to fill in the gap, or the gap may be the result of unintended independent processes that create a demand for additional regulation states can’t immediately deliver.¹²⁰

Authority issues aside, the practical reality of non-state actors has overcome prior reflection.¹²¹ These actors operate in the international sphere, shape agendas, and participate in international law making processes. Their legitimacy is largely tied with their efficacy and outcome. These non-state actors even go beyond the reach of states in certain aspects by effecting change and creating new models for behavior, like determining new standards and policies in human rights, or proposing new environmental regulations.¹²² Non-state actors’ involvement in humanitarian activities has led to the adoption of more and better humanitarian law and policies by states.¹²³ As non-state actors involvement in international law making increases, the level of closed-door diplomacy decreases, making these processes more transparent. Non-state actors increasingly hold specialized knowledge due to their often-singular

¹¹⁶ *Id.*

¹¹⁷ See Bas Arts, *Non-State Actors in Global Governance: Three Faces of Power*, 2003/4 PREPRINTS AUS DER MAX-PLANCK-PROJEKTGRUPPE RECHT DER GEMEINSCHAFTSGÜETER 34 (2003).

¹¹⁸ See Maarten Hajer, *Policy Without Policy? Policy Analysis and the Institutional Void*, 36 POL’Y SCI. 175, 181 (2003).

¹¹⁹ Arts, *supra* note 117.

¹²⁰ Arts, *supra* note 117, at 34.

¹²¹ See Richard Langhorne, *The Diplomacy of Non-State Actors*, 16 DIPL. & STATECRAFT 331, 331 (2005).

¹²² See generally Kristine Kern & Harriet Bulkeley, *Cities, Europeanization and Multi-Level Governance: Governing Climate Change Through Transnational Municipal Networks*, 47 J. COMMON MKT. STUD. 309, 309 (2009).

¹²³ See Cenap Cakmak, *Civil Society Actors in International Law and World Politics: Definition, Conceptual Framework, Problems*, 6 INT’L J. CIV. SOC’Y L. 7, 30 (2008).

grassroots experience and relationship to the conditions affecting communities on the ground.¹²⁴ This unique perspective renders non-state actors crucial for holding governments accountable.¹²⁵ This is particularly evident on issues of economic development, environmental protection, or civilian protection from certain categories of weapons such as antipersonnel landmines.¹²⁶ Insofar as these non-state actors efficiently fill in the intended or unintended public authority and regulation gaps of the state, they gain outcome legitimacy.

It is true that the justification for non-state actors' exercise of governance has been "primarily if not exclusively instrumental."¹²⁷ Non-state actors demonstrate that they can provide "benefits that cannot otherwise be obtained."¹²⁸ Brunkhorst argues that non-state actors may make legitimacy claims based on outcome legitimacy "through the positive effect [they have] for the people or peoples of the world," but they lack process legitimacy due to their lack of democratic participation and control.¹²⁹ What is more, non-state actor involvement in international decision-making has increased the level of scrutiny applied to their process legitimacy. But how do we evaluate this legitimacy?

The way non-state actors operate and manage themselves, including their relationship with their constituencies are factors that would normally apply towards their process legitimacy.¹³⁰ But unlike democratic states, non-state actors have no electoral mandate and thus have not been legitimated by those over whom they claim to exercise political authority.

¹²⁴ See Tim Büthe, *Governance Through Private Authority: Non-State Actors in World Politics*, 58 J. INT'L AFF. 281, 289 (2004).

¹²⁵ Tim Büthe, *Governance Through Private Authority: Non-State Actors in World Politics*, 58 J. INT'L AFF. 281, 289 (2004).

¹²⁶ See *id.*; Asher Alkoby, *Non-State Actors and the Legitimacy of International Environmental Law*, 3 NON-STATE ACTORS & INT'L L. 23, 33 (2003) ("By providing scientific expertise and by exercising their increasing political power, NGOs act to shape the global environmental agenda. Lack of information and scientific uncertainty often become barriers to global efforts to combat environmental degradation. This is why in recent years, NGOs have had the opportunity to play an important role in the processes that led to many of the conferences where international environmental treaties were negotiated and signed."); *id.* at 26 ("Nongovernmental organizations (NGOs), business corporations and other non-state entities have become increasingly influential in international environmental lawmaking processes. They initiate international action to address environmental concerns; influence the negotiating process of treaties and other legal instruments, and help monitor state compliance with international norms. Yet they are usually not afforded legal status, and their roles are generally not secured in international institutional arrangements.").

¹²⁷ Allen Buchanan & Robert O. Keohane, *The Legitimacy of Global Governance Institutions*, 20 ETHICS & INT'L AFFAIRS 405, 422 (2006).

¹²⁸ *Id.*

¹²⁹ Peters et al., *supra* note 109, at 225.

¹³⁰ Matthew Bolton & Thomas Nash, *The Role of Middle Power-NGO Coalitions in Global Policy: The Case of the Cluster Munitions Ban*, 1 GLOBAL POL'Y 172, 181 (2010).

This objection became known as the “global democratic deficit” of non-state actors notably after the 1999 Ministerial Conference of the World Trade Organization when the “international system’s lack of transparency, accountability, and citizen inclusiveness became a major political issue.”¹³¹ This largely shared notion of democratic legitimacy often presumes that the legitimacy of a government and the legitimacy of a non-state actor are of the same kind and attach to the same type of relations with their constituencies. However, the expression of constituencies’ support is different towards governments and non-state actors. While governments receive their public support through elections, public support for non-state actors may be demonstrated through other forms of participation such as membership, voluntary work, endorsement of their strategies and causes, financial donations, or even social media following. The origin of such legitimacy thus differs and attaches to the authority the non-state actor exerts based on their perceived ability to address a certain type of institutional void through its specialized knowledge and expertise, or its exemplary principles and values.¹³²

In a world where non-state actors *de facto* exercise political authority, “there is a direct relationship between the relevant global governance institution and the actors to whom the normative provision is addressed.”¹³³ This not only suggests that non-state actors derive their legitimacy from their position in the global governance system, but also that the system itself derives its legitimacy from the link these non-state actors establish between its institutions and their constituency.¹³⁴ This legitimacy must be offered voluntarily; non-state actors cannot force it but rather attract or inspire it. Their legitimacy will then depend on the period they are capable of retaining the constituency support, which is not guaranteed for a specific time unlike that of the elected government. When the non-state actors lose this support, they then suffer a democratic deficit and cease to be legitimate.

3. Questions of Accountability

As non-state actors gain more significant institutional power, a natural question lingers: to whom are they accountable?¹³⁵ Just like legitimacy, accountability is also a relational concept that is socially and discursively

¹³¹ Andrew L. Strauss, *Considering Global Democracy - An Introduction to the Symposium: Envisioning a More Democratic Global System*, 13 WIDENER L. REV. [i], [i] (2007).

¹³² DEBORAH D. AVANT ET AL., WHO GOVERNS THE GLOBE? 114 (Deborah D. Avant et al. eds., 2010).

¹³³ Peters et al., *supra* note 109, at 232.

¹³⁴ Arts, *supra* note 117, at 34.

¹³⁵ Bütthe, *supra* note 126, at 289.

constituted. Edwards and Hume define it as “the means by which individuals and organizations report to a recognized authority (or authorities) and are held responsible for their actions.”¹³⁶ Other scholars expand this perspective by proposing that accountability is not only about being “held responsible” by others, but also about “taking responsibility” for oneself.¹³⁷ This gives accountability two forms, one external as “an obligation to meet prescribed standards of behavior,”¹³⁸ and one internal as “felt responsibility.”¹³⁹ The objection that non-state actors’ increasing influence is disproportionate because of their lack of accountability is an objection to the role of non-state actors in international law processes. In assessing this objection, framing is of the essence. The answer to the question, “are non-state actors currently adequately accountable?”, the answer is, likely no. But in a world where the role of these actors is not only identified but also understood, the important question to ask is, “can non-state actors become adequately accountable, and how?” This is not to diminish the importance of the accountability critique but to frame the debate in a more constructive manner.

The earlier “subjects doctrine” issue also speaks to accountability. Even though non-state actors are granted key roles within legal and legislative arrangements, their official status under international law remains uncertain. These actors are still relatively undiscovered since states “have not yet agreed on a standard for NGOs [and other non-state actors] operating in the transnational sphere.”¹⁴⁰ But the landscape for non-state actor accountability isn’t as blurry as it may seem. The ILC has adopted the Articles on the Responsibility of International Organizations (RIO)¹⁴¹ setting new baselines regarding wrongful actions,¹⁴² consequences and standards of attribution,¹⁴³ and reparation.¹⁴⁴ The progress made in the International Organizations sphere suggests that accountability deserves greater significance and can be fleshed out with the necessary political will

¹³⁶ Michael Edwards & David Hulme, *Too Close for Comfort? The Impact of Official Aid on Nongovernmental Organizations*, 24 *WORLD DEV.* 961, 967 (1996).

¹³⁷ Andrea Cornwall et al., *Accountability Through Participation: Developing Workable Partnership Models in the Health Sector*, 31 *INST. DEV. STUD. BULL.* 1, 3 (2000).

¹³⁸ Laura B. Chisolm, *Accountability of Nonprofit Organizations and Those Who Control Them: The Legal Framework*, 6 *NONPROFIT MGMT. & LEADERSHIP* 141, 141 (1995).

¹³⁹ Ronald E. Fry, *Accountability in Organizational Life: Problem or Opportunity for Nonprofits?*, 6 *NONPROFIT MGMT. & LEADERSHIP* 181, 181 (1995).

¹⁴⁰ Kerstin Martens, *Examining the (Non-)Status of NGOs in International Law*, 10 *IND. J. GLOBAL LEGAL STUD.* 1, 23 (2003).

¹⁴¹ Int’l Law Comm’n, Rep. on the Work of Its Sixty-Third Session, U.N. Doc. A/CN.4/SER.A/2011/Add.1 (Part 2), at 40 (2011).

¹⁴² *Id.* at Art. 3.

¹⁴³ *Id.* at Art. 6–9.

¹⁴⁴ *Id.* at 42, Art. 31.

and right approach.

NGOs have encountered similar demands for accountability particularly after the Greenpeace-Brent Spar incident. There, Greenpeace was criticized for significantly overstating the potential environmental damage of the Brent Spar oilrig sinking in the North Sea based on a prior environmental impact assessment.¹⁴⁵ Greenpeace was successful in convincing Shell to dismantle the oilrig on land but it was later discovered that sinking it would have been a safer and more environmentally friendly option.¹⁴⁶ This episode not only bruised the credibility and reputation of Greenpeace but also opened up the debate for NGOs' liability under international law. On the other hand, the United Nations Framework Convention on Climate Change (UNFCCC) has successfully developed a "code of conduct," which includes guidelines on "etiquette, safety, and participation in meetings" within its "constituency" system for NGOs.¹⁴⁷ Despite this development, NGOs, like most other non-state actors, do not generally incur legal liability for their actions on the international sphere.¹⁴⁸

But one may question whether the same type of legal liability is in fact a possible or even desirable form of accountability, given the nature of the services and operations some non-state actors provide as public-good entities, and the possible "unrecoverable costs caused by their resistance action."¹⁴⁹ This does not mean that NGOs and other non-state actors should evade all kinds of accountability towards the public, themselves, and their members. Most public institutions are held to a set of standards, which may also extend to non-state actors. Accountability mechanisms that are already in use and can be extended or institutionalized such as reports and disclosure statements, evaluations, performance assessments, self-

¹⁴⁵ See generally INTERNATIONAL LAW ASSOCIATION, *supra* note 103.

¹⁴⁶ See, for an account of the episode: GRANT JORDAN, SHELL, GREENPEACE AND THE BRENT SPAR 12 (2001). Greenpeace still defends that recycling was the best option. See 1995 - *Shell Reverses Decision to Dump the Brent Spar*, GREENPEACE INT'L, <https://www.greenpeace.org/archive-international/en/about/history/Victories-timeline/Brent-Spar/> (last visited Oct. 15, 2019). Sinking would, amongst others, be environmentally friendly, in that it enables coral growth on the decommissioned oil rigs. See Niall Bell & Jan Smith, *Coral Growing on North Sea Oil Rights*, 402 NATURE 601, 601 (1999).

¹⁴⁷ UNITED NATIONS CLIMATE CHANGE SECRETARIAT, GUIDELINES FOR THE PARTICIPATION OF REPRESENTATIVES OF NON-GOVERNMENTAL ORGANIZATIONS AT MEETINGS OF THE BODIES OF THE UNITED NATIONS FRAMEWORK CONVENTION ON CLIMATE CHANGE 1, 2-5 (Mar. 2003). See BARBARA K. WOODWARD, GLOBAL CIVIL SOCIETY IN INTERNATIONAL LAWMAKING AND GLOBAL GOVERNANCE: THEORY AND PRACTICE 311 (2010).

¹⁴⁸ RAINER HOFMANN & NILS GEISSLER, NON-STATE ACTORS AS NEW SUBJECTS OF INTERNATIONAL LAW 81 (1999).

¹⁴⁹ REPHAEL HAREL BEN-ARI, THE LEGAL STATUS OF INTERNATIONAL NON-GOVERNMENTAL ORGANIZATIONS: ANALYSIS OF PAST AND PRESENT INITIATIVES (1912-2012) 60 (2013).

regulation, and social audits are different types of accountability mechanisms that may better fit the different qualities of non-state actors. In the event that these actors fail to meet their standards, they may become subject to sanctions, such as the shrinking size of their membership or support base, the reduction of their financial resources, the shaming and attack on their reputation in the eyes of their peers and public opinion, and decreased media attention and exposure.¹⁵⁰ The Global Accountability Index is one of the relatively new initiatives that measures and compares the accountability of transnational actors including non-state actors based on their transparency, evaluation, participation, and complaint response mechanisms.¹⁵¹ Empirically measuring accountability helps shift the debate into the right direction, from a purely theoretical one to that of tangible analysis and effect. Like the legitimacy objection, the accountability skepticism is certainly present and valid. Instead of discounting non-state actors and their involvement altogether, however, the more constructive shift is to assess how and in what forms accountability may expand to them.

III. MANNERS OF CONNECTION IN NETWORKS

A. *Short Introduction to Network Theory and Analysis*

To establish the framework and the tools that allow us to see international law differently, we need a different kind of perspective and a new methodological approach. The first step we took to this end was to undertake a conceptual shift regarding the kind of structures in which contemporary international law making takes place. The previous part prepared us to view the international system as a web of multiple actors and networks instead of only states as unitary hierarchical actors. In this world, the development of international law is not limited to the boundaries of sovereign power but depends upon the connection, density, and intensity of ties across these boundaries, and among actors.¹⁵² To achieve this shift of our perspective and analysis, this part sets up the methodological framework within which we can examine networks as structures in and of themselves, but also networks as actors in a larger international networked system.¹⁵³ That is because agency and structure are viewed as deeply intertwined and interdependent. Giddens describes this interdependence as the duality of structure, “according to [which] the structural properties of

¹⁵⁰ Peter Grabosky, *Beyond Responsive Regulation: The Expanding Role of Non-State Actors in the Regulatory Process*, 7 REG. & GOVERNANCE 114, 119 (2013).

¹⁵¹ Peters et al., *supra* note 109, at 279.

¹⁵² See Bianchi, *supra* note 86, at 41 n.7.

¹⁵³ SLAUGHTER, *supra* note 71, at 34.

social systems are both medium and outcome of the practices they recursively organize.”¹⁵⁴ Agency is bound by structures at the same time as agency brings about and changes those structures that determine the conditions of action.¹⁵⁵ Analyzing networks of international law making as structures will help us assess how the structure of the network affects the actors within the international law making processes. Examining networks as actors will shed light on the role and impact networks have on the making of international law when they interact with other actors or networks.

Researchers across disciplines have, over the years, also developed a set of tools for understanding networks through analyzing and modeling them. These tools are mathematical, statistical, and computational, and tell us something about a network that may not be visible to the naked eye. In this Part, I will introduce the basic tools used to describe and analyze networks that can be helpful in the process of analyzing international legislative action. Often, these tools start from a simple representation of the network and proceed with a series of calculations that answer different questions such as which actors are best connected, how actors cluster together, and even whether and how resources, information, or normative prescriptions emerge and diffuse in a network. These tools exist in the abstract and may be applied to any system that we can represent in network form. But not all of these tools are useful every time—rather, their usefulness is largely dependent on the network and specific questions the researcher poses. What these measurements and calculations represent, however, is the available toolbox that we can use to address most enquiries in the process of understanding networks in general, and the networks involved in international law making in particular. Most of these tools come from social network analysis and its application of graph theory, the branch of mathematics that addresses networks.¹⁵⁶

First, social network analysis is a collection of ideas, measures, and tools for relational analysis designed to understand the most important features of social structures.¹⁵⁷ Researchers often use it to explore social relations and structures to better conceptualize and organize them but also to understand their material outcomes.¹⁵⁸ The indispensable elements of all networks are actors with relations that represent any contact, connection, or

¹⁵⁴ ANTHONY GIDDENS, *THE CONSTITUTION OF SOCIETY* 25 (1984).

¹⁵⁵ See COLIN WIGHT, *AGENTS, STRUCTURES AND INTERNATIONAL RELATIONS: POLITICS AS ONTOLOGY* 101 (2006).

¹⁵⁶ See ALI KAVEH, *OPTIMAL ANALYSIS OF STRUCTURES BY CONCEPTS OF SYMMETRY AND REGULARITY* 15 (2013).

¹⁵⁷ JOHN SCOTT, *SOCIAL NETWORK ANALYSIS: A HANDBOOK* 85 (3d ed. 2017).

¹⁵⁸ *Id.*

tie between any of at least two of them.¹⁵⁹ Social network analysis focuses on these relationships as they are defined as links among certain nodes. After introducing the basics of social network analysis, I address its metrics for quantifying network structure and discuss some of the most relevant patterns that networks reveal when we apply these social network analysis metrics to the study of networks in international law making.

Second, graph theory comes in to analyze and visualize these connections. Graphs are the mathematical structures used to portray pairwise relations between actors.¹⁶⁰ Remember the seven bridges of the Koningsberg problem? Well, graph theory has made leaps and bounds since Euler's graph assisted with this problem's solution. The main advantage of graphs is their powerful way of representing structured data.¹⁶¹ Graph visualizations thus represent the nodes and links of a network in a way that promotes easier understanding of the structures and relationships represented by the graph. Graph theory will help us transform our multi-dimensional world and its phenomena into a two-dimensional graph of nodes (actors) and edges (links), to quantify these relationships, and to formalize their properties through algorithms. This Article only includes a fraction of graph theory's tools, focusing on the ones that are most relevant to the study of networks responsible for the making of international law. Seeing this different perspective of the world allows us to understand the wide spectrum of actors, structures, and designs involved in international law making today.

Sociologists first used social network analysis to explain social behavior by examining the structural patterns of community ties, hypothesizing that these patterns determined the social behavior of the actors involved.¹⁶² Social network analysis undertakes as the primary unit of inquiry the social relation that connects members in a social system instead of the agents themselves. It is grounded on the intuitive idea that the patterns of social ties that actors are embedded in have important consequences for those actors, and are able to shape their perceptions, attitudes, and actions.¹⁶³ Wasserman and Faust have proposed the four

¹⁵⁹ DAVID KNOKE & SONG YANG, *SOCIAL NETWORK ANALYSIS* 6–7 (2d ed. 2008).

¹⁶⁰ FABRIZIO DE VICO FALLANI & FABIO BABILONI, *THE GRAPH THEORETICAL APPROACH IN BRAIN FUNCTIONAL NETWORKS: THEORY AND APPLICATIONS* 13 (2010).

¹⁶¹ Horst Bunke & Michel Neuhaus, *Graph Matching—Exact and Error-Tolerant Methods and the Automatic Learning of Edit Costs*, in *MINING GRAPH DATA* 17, 17 (Diane J. Cook & Lawrence B. Holder eds., 2006).

¹⁶² Barry Wellman, *Studying Personal Communities*, in *SOCIAL STRUCTURE AND NETWORK ANALYSIS* 61, 63–64 (Peter V. Marsden & Nan Lin eds., 1982).

¹⁶³ Linton C. Freeman, *The Development of Social Network Analysis: A Study in the Sociology of Science*, 27 *SOC. NETWORKS* 377 (2005); KNOKE & YANG, *supra* note 159, at 63–64.

broadly accepted principles of social network analysis:¹⁶⁴ (1) the agents and their actions are not autonomous or independent but rather interdependent;¹⁶⁵ (2) the ties between nodes are the channels through which material or non-material resources flow;¹⁶⁶ (3) the structures of the network may constrain or enable agents' individual action;¹⁶⁷ and (4) network structures may be studied as long-term patterns among the individual nodes.¹⁶⁸ This framework allows for an empirical calculation of the relationships involved, a mapping of these relationships on the basis of connection, a tangible display of the effects these relationships produce within and for the network, and an evaluation of the network structure as a whole.¹⁶⁹

Perhaps the most important benefit of social networks analysis is its ability to escape the narrow vision of the actor-centered analysis we often encounter in international law. Instead of focusing only on the attributes of a single actor or a given number of actors, it targets the associations among these actors,¹⁷⁰ and their ability to enable or constrain agents.¹⁷¹ In this way, social network analysis complements already existing methods by offering an additional lens that focuses on actors' associations. By proposing that patterned relations among actors influence social entities beyond their individual attributes, social network analysis can infuse a theoretical framework with an empirical basis for the sources and effects of social action, including that leading to international law making.¹⁷² By making use of statistical analysis and applying the quantitative tools of linear algebra and graph theory to the identification of organizational structures and their effects,¹⁷³ social network analysis exposes our framework for understanding international law making to an entirely new dimension.

¹⁶⁴ STANLEY WASSERMAN & KATHERINE FAUST, *SOCIAL NETWORK ANALYSIS: METHODS AND APPLICATIONS* 4, 8 (2004).

¹⁶⁵ *Id.*; see also Hafner-Burton et al., *supra* note 88, at 562; Scott D. Gest & Thomas A. Kindermann, *Analysis of Static Social Networks and Their Developmental Effects*, in *HANDBOOK OF DEVELOPMENTAL RESEARCH METHODS* 577, 580 (Brett Laursen et al. eds., 2012).

¹⁶⁶ WASSERMAN & FAUST, *supra* note 164, at 4; Wellman, *supra* note 162; Hafner-Burton et al., *supra* note 88, at 562.

¹⁶⁷ WASSERMAN & FAUST, *supra* note 164, at 4; Wellman, *supra* note 162; Hafner-Burton et al., *supra* note 88, at 562.

¹⁶⁸ WASSERMAN & FAUST, *supra* note 164, at 4; Wellman, *supra* note 162; Hafner-Burton et al., *supra* note 88, at 562.

¹⁶⁹ Hafner-Burton et al., *supra* note 88, at 562–63.

¹⁷⁰ Hafner-Burton et al., *supra* note 88, at 562.

¹⁷¹ Hafner-Burton et al., *supra* note 88, at 560.

¹⁷² IAN MCCULLOH ET AL., *SOCIAL NETWORK ANALYSIS WITH APPLICATIONS* 13 (2013).

¹⁷³ *Id.*

But just like all research methods, social network analysis has its limitations. Its primary limitation stems from the realization that the social and, by extension, the legal worlds, consist of more than just social structures.¹⁷⁴ Social network analysis is constrained to addressing structural relations.¹⁷⁵ Yet many of the issues that relate to the study of social action require an additional set of analytical tools to address aspects that are not as easily quantifiable. For example, intention, rationality, or subjectivity within social environments may influence networks, but these factors are more difficult for social network analysis to assess alone.¹⁷⁶ But even though social network analysis has some analytical limitations, it is open to complement and be complemented by other differently limited approaches.¹⁷⁷ Because of its generality and flexibility, social network analysis can cut across the boundaries of traditional discipline distinction without becoming antagonistic with other disciplines or methods.¹⁷⁸ For instance, as social network analysis does not have data collection methods specific to it, it borrows data collection methodologies from other disciplines.¹⁷⁹ This disciplinary fluidity and the versatility of its methods and tools allow social network analysis to address some of the most complex aspects of social structure and the attributes of individual actors that arise from their relations with others.¹⁸⁰

In social sciences, social network analysis has become a strong methodology that complements standard statistical analysis. It has been defined, applied, and tested in several research fields from anthropology and sociology to organizational behavior and history.¹⁸¹ An “organized

¹⁷⁴ JOHN SCOTT, *WHAT IS SOCIAL NETWORK ANALYSIS?* 85 (2012).

¹⁷⁵ See David Knoke & Song Yang, *SOCIAL NETWORK ANALYSIS* 4–6 (2008).

¹⁷⁶ SCOTT, *supra* note 174; See e.g., Dharshana Kasthurirathna, Michael Harre, and Mahendra Piraveenan, *Influence modelling using bounded rationality in social networks*, in *PROCEEDINGS OF THE 2015 IEEE/ACM INTERNATIONAL CONFERENCE ON ADVANCES IN SOCIAL NETWORKS ANALYSIS AND MINING 2015* 33–4 (Jian Pei, Fabrizio Silvestri, and Jie Tang eds. 2015).

¹⁷⁷ SCOTT, *supra* note 174, at 86; See generally KNOKE & YANG, *supra* note 159.

¹⁷⁸ LINTON C. FREEMAN, *THE DEVELOPMENT OF SOCIAL NETWORK ANALYSIS* 4 (2004) (“The network field has developed important applications in research on: ‘. . . the study of occupational mobility, the impact of urbanization on individuals, the world political and economic system, community decision-making, social support, community, group problem-solving, diffusion, corporate interlocking, belief systems, social cognition, markets, sociology of science, exchange and power, consensus and social influence, and coalition formation . . . primate studies, computer-mediated communication, intra- and inter-organizational studies, and marketing . . . health and illness, particularly AIDS.’”).

¹⁷⁹ Stephen T. Ricken et al., *Tell Us Who: Guided Social Network Data Collection*, *PROC. 43RD HAWAII INT’L CONF. SYS. SCI.* 1 (2010).

¹⁸⁰ Robert Hanneman & Mark Riddle, *Centrality and Power*, *INTRODUCTION TO SOC. NETWORK METHODS* (2005), <https://faculty.ucr.edu/~hanneman/nettext/>.

¹⁸¹ AJITH ABRAHAM ET AL., *COMPUTATIONAL SOCIAL NETWORK ANALYSIS: TRENDS, TOOLS AND RESEARCH ADVANCES* 135 (2009).

paradigm” for a social network analysis enquiry includes an initial structural intuition based on relations that link actors, a strong set of empirical data, reliance on mathematical and computational models, development of graphic imagery and its analysis through visualization.¹⁸² In social network analysis, regardless of whether one is collecting data on larger or smaller networks, one must specify a “boundary” that establishes which actors and relations are included within the network and which ones are excluded.¹⁸³ Without this boundary specification, particularly in larger networks, the number of possible links could increase exponentially as the number of actors increases. This could threaten to both outstrip the ability of the researcher to collect all necessary data and, in particularly large networks, the ability of the hardware and software to process this data computationally.

B. *Why International Law, Why Now?*

What do these methods have to offer to international law making? First, the tools of network theory help us quantify and map actors’ and networks’ contributions to international legislative processes. This descriptive project allows us to clearly map and understand the wide spectrum of actors, structures, and designs involved in international law making. It provides a means to quantify the impact and effect of these actors individually and collectively on the making of international law irrespective of their *de jure* status in international legislative action and *fora*. In other words, this allows us to map states and non-state actors and investigate their actual, instead of expected, contribution to international legislative processes. Finally, network theory can help us to tailor networked solutions to existing international problems so that international legislative action can be more effective.

International law addresses problems that have triggered international legislative action requiring coordination, collaboration, regulation, allocation of resources, responsiveness to threats against the network and the network’s actors, as well as means of normative enforcement and accountability. Network theory will help us map and examine the types of networks that emerge to address these problems through international legislative action, allowing us to recognize the full spectrum of actors involved in international law making and their precise effect. This will offer an empirical basis for current discussions on the role of various actors in international law, including their normative contribution and effect as well as their levels of *de facto* recognition by other actors of the

¹⁸² FREEMAN, *supra* note 178, at 3.

¹⁸³ Edward O. Laumann et al., *The Boundary Specification Problem in Network Analysis*, in RESEARCH METHODS IN SOCIAL NETWORK ANALYSIS 61 (1989).

international system. Thus, these methods make descriptive analytical contributions to international law.

These methods also serve a more prescriptive analytical function for international law. A key question in the study of networks in international law is whether and under what terms networks are more effective at addressing problems through legislative processes than the other two existing structural forms of markets and hierarchies.¹⁸⁴ Network analysis not only allows us to measure and map the dynamics of actors in networks but also provides the springboard on which to build new frameworks for international legislative action. Network analysis paints a much clearer picture of whom to call upon when putting forward a legislative agenda, when to introduce a normative prescription on the basis of the legislative network's social capital,¹⁸⁵ and how to best diffuse it based on the actors involved in each legislative process. Network analysis also helps us determine the most powerful actors or the leaders in various legislative networks, and to quantify the effect of their position to normative development. Finally, network analysis allows us to map how actors influence each other's normative preferences and outcomes, the preferences and outcomes of their networks and other networks, how these actors are likely to act based on the structures they are embedded in, and what they learn from each other. Understanding and integrating these insights is critical to mapping existing international legislative action and prescribing the means to enact successful international legislative action in the future.

And why use these methods in international law now? For decades, quantitative methods in international law boiled down to some primary datasets collected in the field of human rights and analyzed statistically from print or analogue datasets.¹⁸⁶ This was, in part, due to the scarcity of data and the difficulties of obtaining it at the time, and, in part, due to the narrower approach of traditional legal method. But data today has become an increasingly important driver of empirical legal research. The catch-all term "big data" refers to the exponential growth of available data as a product of increasing connectivity through the digital revolution.¹⁸⁷

¹⁸⁴ See Slaughter, *supra* note 71, at 36.

¹⁸⁵ See generally JOHN SCOTT, SOCIAL NETWORKS: CRITICAL CONCEPTS IN SOCIOLOGY 103 (2002); see generally JAMES S. COLEMAN, FOUNDATIONS OF SOCIAL THEORY (1990).

¹⁸⁶ Antoine Nouvet & Frederic Megret, *Quantitative Methods for Human Rights: From Statistics to "Big Data"*, RES. METHODOLOGIES LEGAL HUM. RTS. SCHOLARSHIP (2017).

¹⁸⁷ Various strict quantitative definitions exist (for example: a dataset with over a billion data nodes). Various qualitative definitions exist (such as the dataset's approximation to capturing the entire data population we intend to measure, or the inability for typical database software tools to process data because it is too large, unstructured, and complex). This chapter emphasizes the importance of the digital. This is similar with the UN OHCHR's definition: "Extremely large data sets associated with new information technology and which can be analyzed computationally to reveal possible patterns, trends

Conceptually, big data in legal research is associated with three primary factors: First, the levels of connectivity and information diffusion through the internet have dramatically increased. Next, more than ever before, the advancements in search engines and creation of big databases and repositories are at the disposal of legal scholars. That is why researchers are beginning to become increasingly aware of their ability to treat primary material in the legal discipline as data. Finally, the increased interaction of international law with other disciplines provides international law researchers with new sets of methods and tools for processing large amounts of data, and introduces new approaches to legal enquiry that were less attractive in the past due to scarcity of such data or decreased ability to process it.

1. The Basic Network Properties

In the previous part, a network was defined as a collection of actors called nodes connected by links of relations called edges. When researchers represent networks in Figures, like Figure 1 below, circles represent nodes and lines connecting circles represent edges. A network is also called a “graph” in the language of mathematics. Mathematically, I will abbreviate a graph G as $G = (V, E)$, where V is the set of nodes and E is the set of edges. Then $|V|$ is the total number of nodes, and $|E|$ is the total number of edges in the graph G . If u and v are two nodes belonging to graph G , and there is an edge from u to v , then I write that $(u, v) \in E$, and say that v is a neighbor of u . For simplicity, I write (u, v) to represent the link between u and v , and also write $(u, v) \in G$ to indicate that u and v are linked in and belong to (\in) the network G .

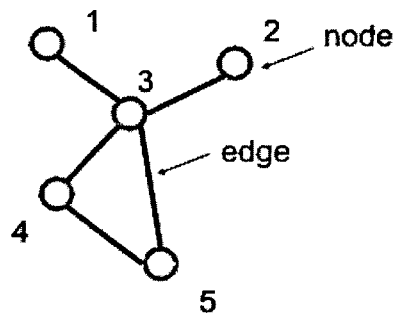

Figure 1

There are many ways to mathematically represent a network. Consider the network in Figure 1 above. It has a given number of nodes that is $n = 5$. If we denote an edge between nodes 1 and 3 by $(1,3)$ then we can describe the complete network by giving the specific number of nodes and a list of all edges. In the network above this is $n = 5$ nodes and edges $(1,3)$, $(2,3)$, $(3,4)$, $(3,5)$, and $(4,5)$. This representation of the edges is called an “edge list” and is useful in storing the data of a network to further analyze computationally. Networks may be directed or undirected depending on whether their edges are directed or undirected. A directed edge means that the edge has an orientation that is typically represented by using an arrow in the graph. In a directed graph, each edge has a certain direction pointing from one node to another node. We may think of directed edges as one-way streets so when traversing a directed edge from node to node we must always travel down the edge as prescribed by the arrow direction. Mathematically, a graph is directed if for any edge a , $a_{u,v} \neq a_{v,u}$ and undirected if $a_{u,v} = a_{v,u}$ for all $u, v \in |V|$. Notice the difference between Figures 1 and 2. Figure 2 below is a directed graph because the edges connecting its nodes indicate the direction with the arrows, while Figure 1 above is an undirected graph.

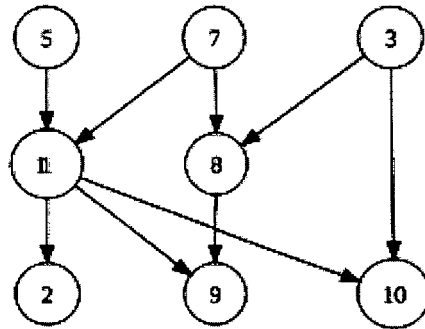

Figure 2

Another way to represent a network is its adjacency matrix. The adjacency matrix is a matrix that describes a graph by representing which nodes are adjacent to which other nodes in the graph. Two nodes are adjacent if they are joined by an edge a . A graph can then be described by its adjacency matrix $A = (a_{u,v})$. This is a square $|V| \times |V|$ matrix with V representing the number of nodes in the graph, where each row and column corresponds to a node of graph G . In this matrix, $a_{u,v} \in \{0,1\}$ represents the availability of an edge from node u to node v . To make the adjacency matrix of a graph we need to start by counting the number of nodes in the graph. Let us take the undirected network in Figure 1 above again. The graph has five nodes, so we need to make our adjacency matrix of size 5 by

5. To make this clearer, we can put the names of the nodes on the top and side of the matrix:

$$A = \begin{array}{ccccc} & \mathbf{1} & \mathbf{2} & \mathbf{3} & \mathbf{4} & \mathbf{5} \\ \mathbf{1} & \left[\begin{array}{ccccc} 0 & 0 & 1 & 0 & 0 \\ 0 & 0 & 3 & 0 & 0 \\ 1 & 1 & 0 & 1 & 1 \\ 0 & 0 & 1 & 0 & 1 \\ 0 & 0 & 1 & 1 & 0 \end{array} \right] & & & & \\ \mathbf{2} & & & & & \\ \mathbf{3} & & & & & \\ \mathbf{4} & & & & & \\ \mathbf{5} & & & & & \end{array}$$

Edges in a network represent the presence of a connection between nodes. Absence of an edge also indicates absence of connection between two nodes. In other words, either that connection exists, or it does not. We represent this by giving these edges binary values based on connection or no connection between two nodes. There are other instances, however, in which the connection itself can give us more information. There is a way to represent edges as having a certain weight or value to them such as, for instance, the amount of data flowing within the edges of an internet network, or the frequency of telephone calls among friends in a social network. In these cases, the edge weight $a_{u,v} > 0$ can take on non-binary values to represent the intensity of the interaction. This means that a graph is a “weighted graph.” In the adjacency matrix, we represent this feature by giving the elements of the matrix values beyond 0,1 equal to the corresponding weight in the connection. When we visualize a graph, we have additional means to represent these quantified variables. In the instance of weight in a graph, we represent it by increasing or decreasing the size or intensity of the color of an edge connecting two nodes. The larger or more intense the edge between two nodes, the higher the weight of that interaction. Also, by extension, the larger or more intense the size or color of a node is, the higher the weight of that node.

When two nodes are connected through a consecutive pair of edges, this represents a “path” in a network. Paths are routes across the graph that run from node to node and represent at least a “two-edge sequence.” In Figure 3, the bolder sequence of edges along four nodes represents a path.

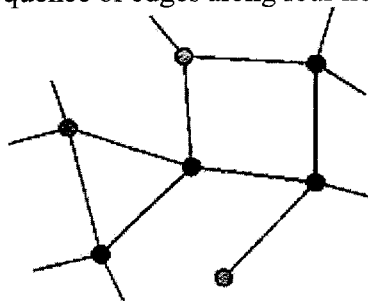

Figure 3

The adjacency matrix entries can tell us for every node v which nodes are within distance 1 of v or in other words connected by an edge to v . To calculate the number of two-step sequences between node u and node v in a graph with adjacency matrix $A = (a_{u,v})$ we calculate for A^2 for two nodes (u, v) with $u \neq v$ in,

$$A^2 = \sum_{v,u \in V} a_{u,v} a_{v,u}$$

If $A^2 \neq 0$ then u can be reached from v within two steps; u is within distance 2 of v . Higher powers can be interpreted similarly. For example, if we wanted to calculate the number of three steps, we would have to raise the adjacency matrix A to the third power of A^3 , perform the same calculation, and so forth. But aside from regular paths, there is also one path that represents the shortest path available in a network between any two nodes. This path is called a “geodesic path.” Naturally, the length of the geodesic path, called the “geodesic distance,” represents the shortest distance between two nodes in a network.

Networks can also be complete or incomplete. For a complete network, the graph is such that every pair of nodes is joined by an edge. The degree deg_v of a node v is the number of edges which involve v as an endpoint, in other words that are connected to it. This degree can be calculated from the adjacency matrix,

$$deg(v) = \sum_u a_{u,v}$$

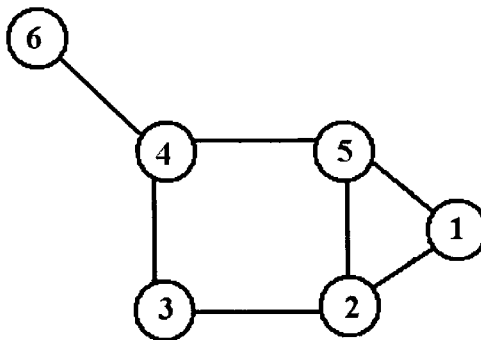

Figure 4

The average degree of a graph then is the average of its node degrees. For instance, in Figure 4, the average degree of node 5 is 3.

The units of analysis in social network analysis represent the varying interactions that link each pair of nodes in the system. The form and content of these linkages directly relate to the properties of the network connections.¹⁸⁸ The links among nodes are not random and their components may reveal distinct substructures within the network as well as particular roles that actors occupy. Identifying, analyzing, and measuring this form and content is part of the necessary methodological task of social network analysis.¹⁸⁹ The variations of network form and content can explain both observed behavior of nodes in the system as well as the social system itself.¹⁹⁰ To best quantify these variations, social network analysis employs a set of metrics as standards for evaluating form and content.

2. The Basic Network Metrics

Being introduced to the nomenclature of network theory and to a set of useful features that capture important aspects of the network structure will improve our understanding of the fundamental structural properties of a network. While a graph can provide a visual for a network that we can compare to other graphs with a quick glimpse, larger networks can be more difficult to envision and describe. To describe and compare these networks, we use a set of quantitative measures that represent some of the networks' properties. Most of these concepts and metrics derive from social network analysis and its application in sociological enquiry. A widely-varied number of other disciplines, however, have adopted most of these tools so that they are now considered part of the basic network toolbox.¹⁹¹ I have selected for discussion some of the measures that are useful in analyzing the network data and in revealing important patterns and features of the international law networks.

i. Centrality

Social scientists have long proposed that power is a fundamental property of social structures.¹⁹² In the study of networked structures, power is inherently relational. The different patterns of relations within networks vest power in different actors and result in varied amounts of power in social structures we study as networks. Social network analysis provides a

¹⁸⁸ SCOTT, *supra* note 157, at 67.

¹⁸⁹ RONALD S. BURT, TOWARD A STRUCTURAL THEORY OF ACTION: NETWORK MODELS OF SOCIAL STRUCTURE, PERCEPTION AND ACTION 22 (1982).

¹⁹⁰ SCOTT, *supra* note 157, at 67.

¹⁹¹ See, e.g., Blaine J. Cole, *Dominance Hierarchies in Leptothorax Ants*, 212 SCI. 83–84 (1981).

¹⁹² Michel Foucault, *The Subject and Power*, 8 CRITICAL INQUIRY 777–95 (1982); DAVE ELDER-VASS, THE CAUSAL POWER OF SOCIAL STRUCTURES: EMERGENCE, STRUCTURE AND AGENCY 1 (2010).

set of concrete tools to approach the notion of power as attached to structural positions of actors within social relations. The metric that social network analysis uses to describe and measure power is “centrality.”¹⁹³ Centrality measures the rough social power of a node based on its connectivity to the rest of the network.¹⁹⁴ It is based on the fundamental premise that the way a node is embedded in the network on the basis of its relations with other nodes impose constraints on that node and offer opportunities.¹⁹⁵ Those nodes that face fewer constraints and have more opportunities are in structurally favorable positions over other nodes in the network.¹⁹⁶ These favorable positions may lead to quicker or more numerous exchanges and greater influence, and may turn a node into a focal point in the network, particularly in relation to other nodes that are in less favored positions.¹⁹⁷

Knocke defines this “network centrality” as “prominence in networks where valued information and scarce resources are transferred from one actor to another.”¹⁹⁸ Centrality measures explain actor positions within a network including the importance and influence their position entails.¹⁹⁹ For instance, a node with high centrality may enjoy easier access to resources or information as opposed to other network nodes. This type of social power does not only allow an actor to access network resources but also increases its influence and effect over network flows. Such a central node would be better positioned to propose, shape, or alter the common interests or norms of the network. In the case of international legislative action, these nodes would be the actors that are key in proposing or shaping normative prescriptions, and those nodes that garner high influence in pushing these prescriptions forward. One of the key goals of analyzing a network is to determine who the most important or central actor in this network is irrespective of their *de jure* status in international law. But there are many ways to understand the notion of “importance,” and network analysis represents these various conceptions in its many measures for centrality. Centrality measures of degree, betweenness, closeness, and

¹⁹³ MCCULLOH ET AL., *supra* note 172, at 52.

¹⁹⁴ *See Id.*

¹⁹⁵ *See* Robert Hanneman & Mark Riddle, *Centrality and Power*, in INTRODUCTION TO SOCIAL NETWORK METHODS (Robert Hanneman ed., 2005).

¹⁹⁶ *See Id.*

¹⁹⁷ Hanneman & Riddle, *supra* note 180, at 7.

¹⁹⁸ DAVID KNONK, POLITICAL NETWORKS: THE STRUCTURAL PERSPECTIVE, STRUCTURAL ANALYSIS IN THE SOCIAL SCIENCES (1990); *See also* Linton Freeman, *Centrality in Social Networks: Conceptual Clarification*, 1 SOCIAL NETWORKS 215–39 (1979); Karen S. Cook et al., *The Distribution of Power in Exchange Networks: Theory and Experimental Results*, 89 AMERICAN JOURNAL OF SOCIOLOGY 275–305 (1983).

¹⁹⁹ MCCULLOH ET AL., *supra* note 172, at 52.

eigenvector can tell us how much influence agents have within their network.²⁰⁰

One of the simplest but most illuminating centrality measures in a network is “degree centrality.” Degree centrality measures the network activity of each node using the concept of degrees, or the number of direct connections of a node. In other words, degree centrality represents the amount of links each node has with other nodes in the network – it is the sum of all links connected to a node.²⁰¹ The more links an actor has, the more power it may have. In directed networks, the number of links going into a node represents “in-degree” centrality, while the number of links originating from it represents “out-degree” centrality.²⁰² In-degree centrality is a measure of importance. A node that receives many ties because other nodes seek to link with it is considered prominent. Actors with high out-degree centrality on the other hand are often characterized as influential because they can exchange with others more easily or disperse information more quickly to other nodes in the network.²⁰³ Mathematically, we can calculate degree centrality for node v ,

$\frac{d_v}{n - 1}$, where d_v is the degree of v and n is the number of nodes in the graph

Based on their degree centrality, nodes with the most ties to other actors hold a special place of influence within the network.²⁰⁴ These nodes are also likely to be less dependent on other nodes in the network.²⁰⁵ For instance, in a social network, individuals with many connections to others often have more access to people or resources, more influence over other nodes or in the network, and more clout than those with fewer connections. In a network with directed ties, the larger a node’s in-degree centrality is, particularly deriving from nodes with high in-degree centrality themselves, the more popular or influential a node is likely to be.²⁰⁶ For instance, a graphic representation of a widely cited scientific paper that effectively represents the measure of the paper’s in-degree centrality in a citation network provides a way to assess the paper’s influence and represents one of the most widely used manners of assessing academic research.

²⁰⁰ *Id.* See also Alex Bavelas, *A Mathematical Model for Group Structures* 7 HUM. ORG. 16 (1948); Linton C. Freeman, *Centrality in Social Networks: Conceptual Clarification*, 1 SOC. NETWORKS 215–39 (1978).

²⁰¹ McCULLOH ET AL., *supra* note 172, at 34.

²⁰² McCULLOH ET AL., *supra* note 172, at 29.

²⁰³ See HANNEMAN & RIDDLE, *supra* note 195, at ch. 10.

²⁰⁴ McCULLOH ET AL., *supra* note 172, at 33.

²⁰⁵ See Hanneman & Riddle, *supra* note 180.

²⁰⁶ Hubert Buch-Hansen, *Social Network Analysis and Critical Realism*, 44 J. THEORY SOC. BEHAV. 309 (2014).

Hafner-Burton and Montgomery posit that actors with higher degree centrality in the international system can “withhold social benefits such as membership and recognition or enact social sanctions such as marginalization as a method of coercion” and would “expect additional support in a conflict.”²⁰⁷ Beckfield argues that actors “with privileged positions in the world polity are able, to a significant degree, to set agendas, frame debates, and promulgate policies that benefit them.”²⁰⁸ The metrics and tools designed to rank nodes based on their position in the network are essential for analyzing and understanding aspects of centrality, interpreting the prominence of a node in a social structure.²⁰⁹

The related metric of “eigenvector centrality” provides a more nuanced approach to degree centrality. While degree centrality determines influence through a simple measure of links per actor, eigenvector centrality is premised on the idea that not all links are of equal value. Links to nodes that are themselves very highly connected will give a certain node more influence than links to nodes that are less connected.²¹⁰ A node will have high eigenvector centrality if it is connected to other highly connected nodes. In other words, the importance of a node likely increases if it is connected to other nodes that are themselves important. Eigenvector centrality is strictly dependent on the degree centrality of the nodes to which a node connects. Instead of awarding nodes one numerical point per connection, it gives each node a numerical score that is proportional to the sum of the scores of the other nodes it connects with.²¹¹ Because of their connectedness to such highly connected nodes, nodes with high eigenvector centrality are also particularly influential nodes in the network.²¹²

Mathematically, beginning with the *adjacency matrix* $A = (a_{u,v})$, where $a_{u,v} \in \{0,1\}$ represents the availability of an edge from node u to node v

$$a_{u,v} = 1 \text{ if and only if } (u, v) \in E$$

²⁰⁷ Emilie M. Hafner-Burton and Alexander H. Montgomery, *Power Positions: International Organizations, Social Networks, and Conflict*, 50 J. CONFLICT RESOL. 11 (2006).

²⁰⁸ Emilie M. Hafner-Burton et al., *Network Analysis for International Relations*, 63 INT’L ORG. 570 (2009).

²⁰⁹ Alex Bavelas, *A Mathematical Model for Group Structures*, 7 HUM. ORG. 16 (1948); Freeman, *supra* note 200, at 215; Ulrik Brandes, *A Faster Algorithm for Betweenness Centrality*, 25 J. MATHEMATICAL SOC’Y 163 (2001).

²¹⁰ MCCULLOH ET AL., *supra* note 172, at 46.

²¹¹ MCCULLOH ET AL., *supra* note 172, at 40.

²¹² MCCULLOH ET AL., *supra* note 172, at 34.

$$a_{u,v} = \begin{cases} 1 & \text{if the nodes } u \text{ and } v \text{ are joined by an edge} \\ 0 & \text{if the nodes } u \text{ and } v \text{ are not joined by an edge} \end{cases}$$

The eigenvector centrality of a node is proportional to the sum of the centralities of the nodes to which it is connected. Suppose that λ is the larger eigenvalue of A and n is the number of nodes in a graph:

$$Ax = \lambda x, \quad \lambda x_u = \sum_{v=1}^n a_{u,v} x_v, \quad u = 1, \dots, n$$

The metric of “betweenness centrality” captures how well situated a node is in terms of the paths it lies on. It represents the extent to which a node lies between other nodes in the same network.²¹³ In other words, betweenness centrality reflects the number of nodes each node connects to indirectly through its edges.²¹⁴ A node with high betweenness centrality has significant influence over what flows between nodes in the network and can thus control the network’s outcomes. Betweenness centrality effectively measures the number of times a node acts as an intermediary, or a bridge, along the shortest path between any other two points.

A node with high betweenness centrality may access or control the flow of information or resources to other nodes in the network because of the “structural hole” it fills, a hole that would otherwise exist between the two other actors that this node connects.²¹⁵ In other words, when two nodes in a network would normally be structurally disconnected, this node serves as a connecting point between them, as a bridge. Betweenness centrality measures how often one given node serves as a bridge in a network.²¹⁶ Because betweenness centrality indicates the amount of control an actor has over what passes through to other nodes of the network,²¹⁷ a node with high betweenness centrality can fill a large number of these structural holes in a network and may play an important role in the network’s structure despite not having high degree centrality.²¹⁸

Betweenness centrality was introduced to quantify the control one person may have on the communication among other people in a social network.²¹⁹ Suppose we have a social network in which rumors are being

²¹³ WASSERMAN & FAUST, *supra* note 164, at 4.

²¹⁴ *Id.*

²¹⁵ See RONALD S. BURT, STRUCTURAL HOLES: THE SOCIAL STRUCTURE OF COMPETITION 65 (1992).

²¹⁶ SCOTT, *supra* note 157, at 47–48.

²¹⁷ *Id.*

²¹⁸ SCOTT, *supra* note 157, at 42.

²¹⁹ Linton C. Freeman, *A Set of Measures of Centrality Based upon Betweenness*, 40 SOCIOMETRY 36, 40 (1977); Jac M. Anthonisse, *The Rush in a Directed Graph*, STICHTING

passed from one person to another. Let us assume that every pair of nodes in this network exchanges a message with equal probability per unit time. Nodes with higher betweenness centrality are the ones through which the largest number of messages pass making them privy to the highest amount of information in this network. These nodes have considerable influence in the network by virtue of the control over information passing to other nodes. Removal of these nodes will also cause the most disruption in this network by severing the paths on which so many of these messages flow. Power in betweenness is premised on the capacity of an actor to broker contacts among other actors, to prevent such contacts, or to isolate actors. In the context of international law making, nodes with higher betweenness centrality can be those key actors that facilitate the information sharing and normative diffusion within a network. Similarly, they are also the actors whose absence may suggest lower levels of information exchange or higher levels of disruptions in normative diffusion.

Mathematically, betweenness centrality can be represented as,

$$C_v = \sum_{v \neq u \neq w \in V} \frac{\sigma_{u,w}(v)}{\sigma_{u,w}},$$

where C_v is the betweenness centrality value at node v , $\sigma_{u,w}(v)$ is the number of shortest paths between nodes u and w that pass through the node v , and $\sigma_{u,w}$ is the number of shortest paths between node u and w .

The last measure of centrality I introduce here is closeness centrality, which is used as a measurement of “global centrality.” Closeness centrality reflects the distance between elements in a defined network space. While two nodes may have fewer connections than other nodes, the pattern of their links may allow them to access all nodes in the network more quickly and efficiently than other nodes.²²⁰ This closeness allows these nodes to better monitor the network’s flow. Closeness centrality quantifies how quickly a node can reach all the other nodes of the network by measuring the mean distance from a node to other nodes. Closeness centrality also represents the influence range of a node by assessing the set of nodes that are reachable from that node. Closeness centrality is higher for nodes that are separated from other nodes only by a shorter distance on average.

In a social network, a person with lower average distance will find it easier and faster to reach others in the network than someone with higher average distance. Closeness is the inverse of the sum of the shortest distances between each node and every other node in the network. The way to measure this is by calculating the aggregate distance from each

MATHEMATISCH CENTRUM. MATHEMATISCHE BESLISKUNDE BN 9/71 (1971).

²²⁰ SCOTT, *supra* note 157, at 49.

node to all other nodes in the network. This can tell us how close a node is likely to be to any other randomly selected node in the network.²²¹ The node that has the lowest aggregate distance is the most central network point with the highest closeness centrality. The nodes with the highest measure of closeness centrality are the ones with the best view of what is happening in this network.²²² Power based on closeness is linked to exchange and bargaining but also to the ability of actors to exert power by serving as the focal point whose views influence a larger number of actors within the network.

To calculate closeness centrality mathematically, suppose that d_{uv} is the length of a geodesic path from node u to node v and n the number of nodes in a network. As mentioned earlier, a geodesic path is the shortest path available in a network between any two nodes and the length of the geodesic path, called the geodesic distance, represents the shortest distance between two nodes in a graph. The mean geodesic distance l from u to v , averaged over all nodes n in the network is,

$$l_u = \frac{1}{n} \sum_v d_{uv}$$

The mean distance l between this pair of nodes (u, v) ,

$$l_{uv} = \frac{1}{n^2} \sum_{uv} d_{uv} = \frac{1}{n} \sum_u l_u$$

And the closeness centrality for node v is

$$\frac{n-1}{\sum_{u \neq v} l(u, v)}, \text{ where } l(u, v) \text{ is the distance between } u \text{ and } v$$

ii. Connectivity

While centrality helps identify power in a network, connectivity helps us answer questions of how connected parts of the network are to one another and to measure the resilience of a network against disruptions. Some networks of individuals are well-connected and are therefore more cohesive, and others are not. In the social networks we engage with daily, certain people have more connections than others. More connections often result in more exposure to information, experience, or resources and make highly-connected individuals more influential. High rates of connection within groups also lead to, for example, a quicker spread of information

²²¹ SCOTT, *supra* note 157, at 42.

²²² SCOTT, *supra* note 157, at 49.

within the group or more and faster mobilization of actors in the face of a problem that requires solution.

Connectivity is often defined as the set of mechanisms, processes, systems and relationships that link individuals and collectives by facilitating material, informational, or social exchange.²²³ It includes physical, technological, as well as social interactions and their outcomes.²²⁴ In a network, a pair of nodes is said to be connected when linked directly or indirectly by an unbroken path.²²⁵ If it is possible to establish a path from any node to any other node in the network, then the network is connected. If it is impossible to connect all nodes with at least one other node in the network, the network is disconnected. The aggregate connectivity of a network is the average cumulative fraction of the nodes reached as the steps performed by nodes to connect to other nodes approach infinity. The more connected a network is, the more likely it is for a random pair of nodes to be connected to one another.²²⁶

The connectivity of individual nodes within a network typically varies. Based on their relative connectivity, nodes can be distinguished as hubs and non-hubs. Hubs are those nodes that are connected to most other nodes in the network.²²⁷ Removing a hub or hubs from a network can cause significant levels of fragmentation in this network.²²⁸ Nodes connect through paths. The average shortest path length describes how “globally connected” a graph is. Mathematically, a path from node v_0 to node v_n takes the form of an alternating sequence of nodes v and edges e , $(v_0, e_1, v_1, e_2, \dots, v_{n-1}, e_n, v_n)$ such that the endpoints of e_i are v_{i-1} and v_i for $i = 1, \dots, n$. The distance $l_{u,v}$ between two nodes u and v is the length of the shortest path joining them. In a connected graph, the average shortest path length is defined as:

$$l = \frac{1}{|V|(|V| - 1)} \sum_{u \neq v \in V} l(u, v)$$

The basic metrics for connectivity in a network are density and transitivity, also known as clustering coefficient. Density reflects the ratio

²²³ See R. DIESTEL, *GRAPH THEORY* 12 (2005).

²²⁴ See J. L. GROSS & JAY YELLEN, *HANDBOOK OF GRAPH THEORY* 335 (2004).

²²⁵ EDWARD O. LAUMANN ET AL., *THE SOCIAL ORGANIZATION OF SEXUALITY: SEXUAL PRACTICES IN THE UNITED STATES* 271 (2000).

²²⁶ *Id.* at 272.

²²⁷ Richard Medina & George Hepner, *Geospatial Analysis of Dynamic Terrorist Networks*, in *VALUES AND VIOLENCE: INTANGIBLE ASPECTS OF TERRORISM* 151, 151 (Ibrahim A. Karawan et al. eds., 2008).

²²⁸ *Id.* at 152.

of actual links over all possible links in a network.²²⁹ Transitivity examines triadic relationships (e.g. the connection between node *A* and node *C*, where node *B* is connected to both separately) and the balance within such relations.²³⁰ These measures account mostly for the inevitable fluctuations in relationships among nodes taking place over time.²³¹ So that we can quantify these fluctuations in our network analysis, I describe these metrics in greater detail here.

a. Density

“Density” reflects the “connectedness” of an actor’s network.²³² It represents the ratio of the actual number of links in a network over the potential number of links in it.²³³ For instance, if many of the nodes to which a node connects are also separately connected with each other, then the density of the network is higher.²³⁴ Density is a useful metric of connectivity because it measures the extent to which a node’s immediate contacts are mutually connected. In social network terms, the more of my friends who are also friends with one another, the greater the density of my network.²³⁵ Thus, density is a good indication of the network’s cohesion and by extension the cost-efficiency, effectiveness, and speed within which information and resources flow and spread within a network. Mathematically, a network can have at most $n \times \frac{n-1}{2}$ edges so its density is $2 \times \frac{|E|}{n \times (n-1)}$, where n is the number of nodes in a graph and E and is the total number of edges.

We can use density to assess various themes and questions in network analysis but it is primarily instructive in establishing the extent of spread in a network, that is, the number of nodes affected by the diffusion of things like information, resources, and norms initiated by a single or set of nodes.²³⁶ For networks of international law making, density allows us to

²²⁹ In a network with “ n ” actors “density” is reflected by $n(n-1)$.

²³⁰ See Hanneman & Riddle, *supra* note 180. See also T.A.B. SNIJDERS, TRANSITIVITY AND TRIADS (2012).

²³¹ RIIKKA VUOKKO & HELENA KARSTEN, WORKING WITH TECHNOLOGY IN COMPLEX NETWORKS OF INTERACTION, ORGANIZATIONAL DYNAMICS OF TECHNOLOGY-BASED INNOVATION: DIVERSIFYING THE RESEARCH AGENDA 334 (2007).

²³² See Maarten de Laat, Vic Lally, Lasse Lipponen & Robert-Jan Simons, *Investigating Patterns of Interaction in Networked Learning and Computer-Supported Collaborative Learning: A Role for Social Network Analysis*, 2 INT’L J. COMPUTER-SUPPORTED COLLABORATIVE LEARNING 87, 87-103 (2007).

²³³ SCOTT, *supra* note 157, at 90.

²³⁴ See ELIZABETH BOTT, FAMILY AND SOCIAL NETWORK: ROLES, NORMS AND EXTERNAL RELATIONSHIPS IN ORDINARY URBAN FAMILIES 97 (1957).

²³⁵ SCOTT, *supra* note 157, at 40.

²³⁶ Habiba Habiba & Tanya Berger-Wolf, *Working for Influence: Effect of Network Density and Modularity on Diffusion in Networks*, IEEE 11TH INTERNATIONAL CONFERENCE

look at how easily or quickly a new normative prescription can reach other nodes within the network. The literature on networks, statistical models, and epidemiology of infectious diseases has also introduced the concept of “effective density” to account for the correlation of density and spread.²³⁷ This measure of effective density is useful in international law making networks to assess the probability of a normative effect within a network.

Effective density also allows us to assess the optimal spreaders in a network, in other words those nodes that have the capacity to maximize the extent of a spread of resources, information, and anything else that might flow through the network. Networks, however, may not always have particularly influential nodes, and thus effective density may not always be a relevant measure in the analysis. Habiba and Berger-Wolff’s epidemiological study found that in networks with low effective densities (“ $\leq .004$ for real networks and $\leq .001$ for synthetic” or artificial networks) a spread will always be low irrespective of who generates it or the sophistication of the approach.²³⁸ Due to the undefined structure, low connectivity, and skewed degree distribution of such networks, most nodes have few or no neighbors and are not able to send or receive a spread. Only hubs or nodes with high-weighted degrees are able to influence but there are so few of them and the nodes of the network have such low degrees that they hardly make a difference.²³⁹ Similarly, the researchers observed that, in networks with high densities (≥ 0.25 for real networks and $\geq .0035$ for synthetic networks), most nodes are well connected and a spread by any random node is high and comparable to a maximum spread due to the high similarity in connectivity of nodes.²⁴⁰ In such a network, spreads behave “almost deterministically” and are likely to affect the entire network, with the effect growing as density increases.²⁴¹ Finally, the study found that in networks of intermediate densities there is a difference over

ON DATA MINING WORKSHOPS 4 (2011).

²³⁷ *Id.*; see also David Kempe et al., *Maximizing the Spread of Influence Through a Social Network*, PROCEEDINGS NINTH ACM SIGKDD INT’L CONF. KNOWLEDGE DISCOVERY & DATA MINING (2003); B. Aditya Prakash et al., *Virus Propagation on Time-Varying Networks: Theory and Immunization Algorithms*, JOINT EUROPEAN CONF. MACHINE LEARNING & KNOWLEDGE DISCOVERY DATABASES (J.L. Balcazar et al. eds., 2010); Hanghang Tong et al., *On the Vulnerability of Large Graphs*, IEEE 10TH INT’L CONFERENCE ON DATA MINING 1091–1096 (2010); Nicholas C. Valler et al., *Epidemic Spread in Mobile Ad Hoc Networks: Determining the Tipping Point*, INT’L CONF. RES. NETWORKING (2011); see also DAVID KEMPE ET AL., MAXIMIZING THE SPREAD OF INFLUENCE THROUGH A SOCIAL NETWORK (2015).

²³⁸ Habiba & Berger-Wolf, *supra* note 236, at 5.

²³⁹ *Id.*

²⁴⁰ *Id.*

²⁴¹ *Id.*

the extent to which the spread is sensitive to the identity of the initiator.²⁴² In sum, in low-density networks, higher spread can likely be achieved only by high-degree nodes. In very dense networks, any node can initiate a spread that can potentially reach most if not all of the network.²⁴³ Knowing the density of a network allows us to know whether there are nodes in a network that are particularly influential over others, that their influence can reach a maximum number of nodes in a network, and how to identify them.

But density is also limited as a measure of comparative social structure in an important way. Given its quality, density varies with the size of a network. This is because it is highly unlikely that actors can sustain an unlimited number of relationships with other actors due to limitations of resources such as time, social interaction, and outreach.²⁴⁴ In other words, very large networks are potentially less dense as it is less likely that actors can build and maintain an exponentially large number of connections. All other things being equal, an increase in the number of actors in a network beyond a certain size will automatically lead to a respective decrease in its density.²⁴⁵ Some of the networks we encounter in international law making may be such large networks in which case looking at density is an important but not conclusive element in identifying the influence of their nodes.

b. Transitivity / Clustering Coefficient

The most fundamental connection among nodes in a network is the link between a pair of nodes, what we have been calling an edge. A collection of nodes that have a connection with each other through one edge and are directly adjacent is called a “neighborhood.” A relation between nodes becomes transitive when, for instance node *u* is connected to node *v*, and node *v* is connected to node *w*. Node *u* is thus also effectively connected to node *w*, but through a transitive relationship. The transitivity of node *u* then is the proportion of neighbors of *u* which are neighbors themselves. In social network terms, the friend of my friend is also my friend. Perhaps the fact that *u* knows *v* and *v* knows *w* doesn’t necessarily mean that *u* knows *w*, but it makes it more likely that the friend of my friend is also my friend than some other randomly chosen member of the network. This effectively creates a set of triangular relationships that are then used to measure a variable we call the clustering coefficient.

²⁴² *Id.*

²⁴³ Habiba & Berger-Wolf, *supra* note 236, at 7–8.

²⁴⁴ Edward O. Laumann et al., *The Boundary Specification Problem in Network Analysis*, in APPLIED NETWORK ANALYSIS 20 (Ronald Burt & Michael Minor eds., 1983).

²⁴⁵ See SCOTT, *supra* note 157, at 43–44.

Mathematically, we measure the clustering coefficient of a node v , where $\sum_{u,w \in V} a_{u,v} a_{w,v} a_{u,w}$ is the number of triangles involving v in the graph,

$$C(v) = \frac{\sum_{u,w \in V} a_{u,v} a_{w,v} a_{u,w}}{\sum_{u,w \in V} a_{u,v} a_{w,u}}$$

The average clustering coefficient is then defined as,

$$C = \frac{1}{|V|} \sum_{v \in V} C_v$$

iii. Similarity or Equivalence

A more abstract aspect of understanding patterns of relations within networks is that of similarity.²⁴⁶ In what way are certain nodes similar to each other and how can we quantify this similarity? Notions of similarity force us to think about actors not only individually as entities but also within sets of categories. We can identify these categories, but also single out principles that apply to those categories and their actors. In this process, we search for those actors that are most similar and, in turn, try to systematize what makes them similar, what makes them different, and from which other actors or categories of actors they differ. In social network analysis, we base this taxonomy on similarities of patterns of relations among actors rather than individual actor attributes.²⁴⁷ These often represent the “social roles” and “social positions” actors might share, or similar building blocks that provide regularities in patterns of relations among them.²⁴⁸ For example, the social role of a “husband” typically implies a patterned set of interactions with a member of other social categories such as “wife,” “husband,” or “child.”

Social network analysis translates this idea in suggesting that similar nodes may be connected to the same or similar nodes and can therefore be substitutable if one fails or decides to leave the network.²⁴⁹ There are two main approaches to understanding similarity in networks: regular equivalence and structural equivalence. Two nodes in a network are

²⁴⁶ HOLTON, *supra* note 36, at 55.

²⁴⁷ See generally A. James O'Malley & Peter V. Marsden, *The Analysis of Social Networks*, 8 HEALTH SERV. & OUTCOMES RES. METHODOLOGY 222 (2008).

²⁴⁸ WASSERMAN & FAUST, *supra* note 164, at 463.

²⁴⁹ See Noah E. Friedkin, *Structural Cohesion and Equivalence Explanations of Social Homogeneity*, 12 SOC. METHODS & RES. 235 (1984); Ronald S. Burton, *Social Contagion and Innovation: Cohesion Versus Structural Equivalence*, 92 AM. J. SOC. 1287, 1291 (1987); Mark S. Mizuchi, *Cohesion, Equivalence, and Similarity of Behavior: A Theoretical and Empirical Assessment*, 15 SOC. NET. 275, 279, 282–3 (1993).

regularly equivalent if they have similar neighboring nodes.²⁵⁰ For instance, two law professors at different universities may not have any friends in common but they may be similar in that they each know a lot of other law professors, law students, administrative staff, and so forth. Structural equivalence on the other hand is established if two nodes share many of the same network nodes.²⁵¹ Two professors at the same law school, for instance, who share many of the same colleagues are often structurally equivalent. Measures of structural equivalence are generally more frequent and better developed than regular equivalence.

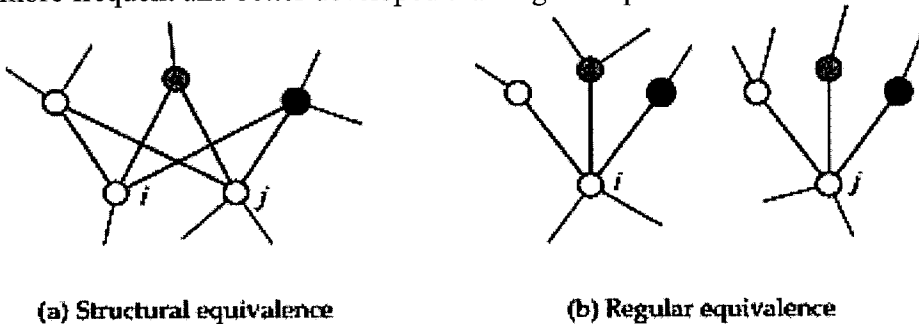

Figure 5

The idea behind structural equivalence is to identify uniform actions and links that define certain social positions within a network.²⁵² Lorrain and White first introduced structural equivalence in social network analysis as a metric of identifying equivalent nodes.²⁵³ They define two nodes as structurally equivalent if they have the same relations linking them to the same nodes in the network.²⁵⁴ Structural equivalence in this sense is the presence of identical ties to and from specific network actors.²⁵⁵ Lorrain and White understand structurally equivalent nodes as interchangeable in the network in which these nodes operate.²⁵⁶ Exactly structurally equivalent nodes are substitutable since they mirror each other's'

²⁵⁰ Ruoming Jin et al., *Scalable and Axiomatic Ranking of Network Role Similarity*, 8 ACM TRANSACTIONS KNOWLEDGE DISCOVERY FROM DATA 1, 6 (2014).

²⁵¹ *Id.*

²⁵² SCOTT, *supra* note 157, at 126.

²⁵³ SCOTT, *supra* note 185, at 129.

²⁵⁴ Lee Douglas Sailer, *Structural Equivalence: Meaning and Definition, Computation and Application*, 1 SOC. NETWORKS 73, 76 (1978).

²⁵⁵ WASSERMAN & FAUST, *supra* note 164, at 366.

²⁵⁶ See Noah E. Friedkin, *Structural Cohesion and Equivalence Explanations of Social Homogeneity*, 12 SOC. METHODS & RES. 235 (1984); Ronald S. Burton, *Social Contagion and Innovation: Cohesion Versus Structural Equivalence*, 92 AM. J. SOC. 1287, 1291 (1987); Mark S. Mizruchi, *Cohesion, Equivalence, and Similarity of Behavior: A Theoretical and Empirical Assessment*, 15 SOC. NETWORKS 275, 278–79, 282 (1993).

relationships to all other nodes. In Figure 6, nodes *E* and *F* each have a single link to node *B* and an identical pattern of ties that makes them structurally equivalent. The same applies to nodes *H* and *I* as they too occupy identical positions in the diagram.

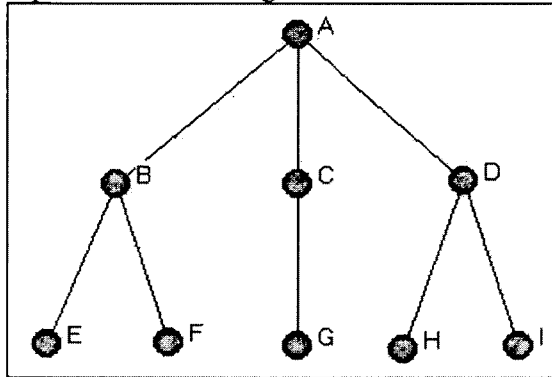

Figure 6 Wasserman-Faust network to illustrate equivalence classes²⁵⁷

More recent work in social network analysis suggests that exact structural equivalence is very rare, especially in larger networks.²⁵⁸ Based on this insight, newer models for structural equivalence have become less strict.²⁵⁹ These models examine the degree of structural equivalence rather than merely the presence of exactly identical ties.²⁶⁰ These analyses of structural equivalence, instead of searching for identical relations, aim to find actors who are sufficiently similar in order to be regarded as structurally equivalent.²⁶¹ The researcher must decide what threshold to apply in establishing which actors to regard as sufficiently similar to deem structurally equivalent and, as a consequence, substitutable.²⁶² Actors in a network may occupy positions of structural equivalence without the rest of the network's actors knowing or having recognized this effect. New roles often emerge in a network in this way: the actions and relations among agents may begin to crystallize into these roles before the rest of the network fully perceives these roles for what they are. Identifying structurally equivalent actors is one way of identifying such emerging roles

²⁵⁷ See generally Hanneman & Riddle, *supra* note 180.

²⁵⁸ See generally Noah E. Friedkin, *Structural Cohesion and Equivalence Explanations of Social Homogeneity*, 12 SOC. METHODS & RES. 235 (1984); Ronald S. Burton, *Social Contagion and Innovation: Cohesion Versus Structural Equivalence*, 92 AM. J. SOC. 1287, 1291 (1987); Mark S. Mizruchi, *Cohesion, Equivalence, and Similarity of Behavior: A Theoretical and Empirical Assessment*, 15 SOC. NETWORK 275, 279, 282-3 (1993).

²⁵⁹ WASSERMAN & FAUST, *supra* note 164, at 364-65.

²⁶⁰ Hanneman & Riddle, *supra* note 180, at 200.

²⁶¹ SCOTT, *supra* note 157, at 123.

²⁶² *Id.*

in a network.²⁶³

There are two primary models for measuring structural equivalence. First, White and Lorrain's model measures the structural equivalence of two actors by correlating the columns of an adjacency matrix.²⁶⁴ The higher the coefficient correlation between a pair of columns and actors, the more structurally equivalent these actors are.²⁶⁵ This original construction of social equivalence was mainly a means of describing the characteristics of social structures. Later, Burt began to utilize the concept of structural equivalence to predict the behavior of actors based on their social roles.²⁶⁶ According to Burt's model, structurally equivalent actors would be more likely to behave similarly than even actors that have been grouped together on the basis of interests, identity, or cohesion.²⁶⁷ This idea provides the major insight of measures of structural equivalence: by knowing the structurally equivalent actors in a network, we can predict to an extent the behavior of all of those actors if we know how one of them behaves.

To mathematically calculate for either model of structural equivalence, we first need to understand it in sets. A set is a collection of objects that represent the elements or members of that set. Two sets, A and B , are defined to be equal when they have precisely the same elements; that is, if every element of A is an element of B and every element of B is an element of A . If sets A and B are equal, then we write $A = B$. The elements of the sets can be anything but in the case of networks the elements for our sets are the nodes in the network. The intersection $A \cap B$ of two sets A and B represents the set that contains all elements of A that also belong to B , or all elements of B that also belong to A , but no other elements. The union $A \cup B$ of two sets A and B represents the set of those elements that are either in A , or in B , or in both.

We measure the similarity of two sets A and B with the Jaccard index. The Jaccard index, also known as the Jaccard similarity coefficient, is a statistic measure for comparing the similarity and diversity of sample sets. In the Jaccard index, we represent the similarity of A and B ,

²⁶³ SCOTT, *supra* note 157, at 122.

²⁶⁴ See JOHN SCOTT, 4 SOCIAL NETWORKS: CRITICAL CONCEPTS IN SOCIOLOGY 129 (2002).

²⁶⁵ Mark S. Mizruchi, *Cohesion, Equivalence, and Similarity of Behavior: A Theoretical and Empirical Assessment*, 15 SOC. NETWORKS 275, 282 (1993).

²⁶⁶ BURT, *supra* note 189, at 22.

²⁶⁷ See Ronald S. Burt, *Cohesion Versus Structural Equivalence as a Basis for Network Subgroups*, in APPLIED NETWORK ANALYSIS: A METHODOLOGICAL INTRODUCTION 262, 272 (Ronald S. Burt & Michael J. Minor eds., 1983); see also Joseph Galaskiewicz & Ronald S. Burton, *Interorganization Contagion in Corporate Philanthropy*, 36 ADMIN. SCI. Q. 88 (1991); BURT, *supra* note 189, at 190.

$$J(A, B) = \frac{|A \cap B|}{|A \cup B|}$$

We say that A and B are disjoint if A does not intersect B , in other words, if they have no elements in common. If A and B are disjoint then $J(A, B) = 0$. If $A = B$ then $J(A, B) = 1$. Given two nodes u and v in a graph, the Jaccard index provides a simple and useful way to compare the similarity of their neighborhoods. The structural equivalence of two nodes u and v is the similarity of their neighborhoods, as measured by the Jaccard index:

$$SE(u, v) = J(u, v) = \frac{|u \cap v|}{|u \cup v|}$$

$$= \begin{cases} 1 & \text{when } u \text{ and } v \text{ have identical neighborhoods} \\ 0 & \text{when the neighborhoods of } u \text{ and } v \text{ are disjoint} \end{cases}$$

iv. The Basic Network Topologies

The form and structure of a network are highly dependent on the metrics of the network nodes and nodes' connections. Graph theory describes how these metrics and connections structurally position nodes by visualizing them and compiling them in certain types of topologies. While these topologies are as manifold as the possibilities of connection within a network, I address here some of the most frequent ones that we often encounter when analyzing networks.

a. Point-to-Point Network

When two nodes are connected through an edge, the link between them is called a point-to-point link. Networks that consist of point-to-point links are called point-to-point networks. To better understand this concept, we can think of a computer network. Such a network typically involves one station that is configured to receive a connection and another station that initiates the connection. Within this network and in between the two stations, point-to-point links operate as dedicated circuits between the stations to achieve higher data transfer rates.²⁶⁸ We also find point-to-point networks in the airline industry: it is the simplest type of network architecture that connects each origin with another via a one non-stop flight.²⁶⁹ A point-to-point network in the airline industry has traditionally

²⁶⁸ MICHAEL E. WHITMAN ET AL., *GUIDE TO NETWORK SECURITY* 280 (2012); see also JEFF MESNIL, *MOBILE AND WEB MESSAGING: MESSAGING PROTOCOLS FOR WEB AND MOBILE DEVICES* 3 (2014).

²⁶⁹ Gerald N. Cook & Jeremy Goodwin, *Airline Networks: A Comparison of Hub-and-Spoke and Point-to-Point Systems*, 17 J. AVIATION/AEROSPACE EDU. & RES. 2, 55 (2008).

been understood as the most unbundled, low-cost, and homogenous service.²⁷⁰

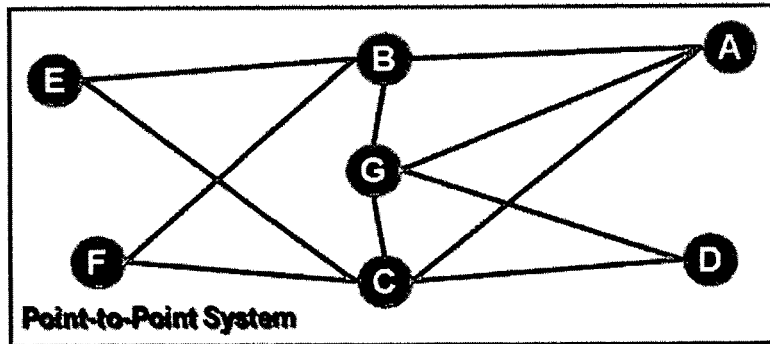

Figure 7

In terms of network architecture, point-to-point networks can have a line, tree, star, ring, or mesh topology. The line structure is the simplest form of network structure in which every node connects with one path to the next node in sequence.

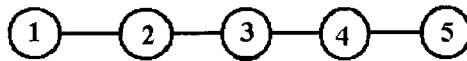

Figure 8

In a tree network, two nodes have exactly one path between them. It often represents a hierarchical structure that stems from a principal node called the tree root, which forms a common link for multiple nodes, connected by several branches.²⁷¹

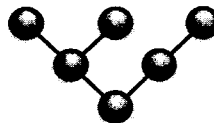

Figure 9

²⁷⁰ Eldad Ben-Yosef, *The Evolution of the US Airline Industry: Technology, Entry, and Market Structure – Three Revolutions*, 72 J. AIR L. & COMM., 305, 325 (2007).

²⁷¹ Samuel Pierre, *Intelligent and Heuristic Approaches and Tools for the Topological Design of Data Communication Networks*, in DATABASE AND DATA COMMUNICATION NETWORK SYSTEMS: TECHNIQUES AND APPLICATIONS 289, 295 (Cornelius T. Leondes ed., 2002).

The star topology is also a tree kind of topology but one that contains one central node—the star—that is connected by a point-to-point link to all other nodes of the network.²⁷²

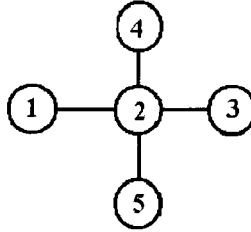

Figure 10

In a ring topology, each node connects to exactly two other nodes forming one single continuous pathway. In other words, all nodes form a closed ring within which each node is connected to the next one in the circle.²⁷³

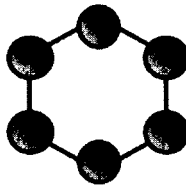

Figure 11

Finally, nodes form a mesh topology when each pair of nodes in a network is linked by more than one path.²⁷⁴

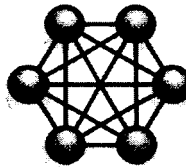

Figure 12

²⁷² *Id.*

²⁷³ *Id.*

²⁷⁴ *Id.*

b. Hub-and-Spoke Network

While point-to-point networks are often the basic network architecture, point-to-point links tend to become part of centralized or distributed network structures that include nodes connected directly or through more centralized nodes called hubs.²⁷⁵ Such networks take the form of hub-and-spoke networks. Based on their relative connectivity, nodes are classified as hubs and non-hubs. Nodes with higher degrees of connectivity are defined as hubs.²⁷⁶ In other words, a hub is a node with a larger number of links surrounded by nodes that have fewer links, also known as non-hubs.²⁷⁷ Hubs are those nodes that have the most structured and intense relationships to other nodes in the network and functionally become “privileged nodes.”²⁷⁸ They are the network’s strongest links.²⁷⁹ Hubs’ structural position within the network facilitates connectivity between interacting nodes.²⁸⁰ Hubs are thus the main means of information management, exchange,²⁸¹ and cooperation in a network.²⁸² A hub concentrates the network flow not only spatially but also temporally, and maximizes connectivity.²⁸³

The notion of hubs is used in many disciplines and sectors: hub-and-spoke free trade agreements;²⁸⁴ medical research networks;²⁸⁵ education;²⁸⁶

²⁷⁵ Ben-Yosef, *supra* note 270, at 326.

²⁷⁶ ASFAR S. AZMI, *SYSTEMS BIOLOGY IN CANCER RESEARCH AND DRUG DISCOVERY* 173 (2012).

²⁷⁷ Kyaw Tun et al., *Rich Can Get Poor: Conversion of Hub to Non-Hub Proteins*, 2 *SYS. AND SYNTHETIC BIOLOGY* 75 (2008).

²⁷⁸ PETER J. TAYLOR, *WORLD CITY NETWORK: A GLOBAL URBAN ANALYSIS* 26 (2004).

²⁷⁹ RICHARD KOCK & GREG LOCKWOOD, *SUPERCONNECT: HARNESSING THE POWER OF NETWORKS AND THE STRENGTH OF WEAK LINKS* 67 (2011).

²⁸⁰ Morton E. O’Kelly, *A Geographer’s Analysis of Hub-and-Spoke Networks*, 6 *J. TRANSP. GEOGRAPHY* 171 (1998).

²⁸¹ Tun et al., *supra* note 277, at 79.

²⁸² KOCK & LOCKWOOD, *supra* note 279.

²⁸³ GUILLAUME BURGHOUWT, *AIRLINE NETWORK DEVELOPMENT IN EUROPE AND ITS IMPLICATIONS FOR AIRPORT PLANNING* 15 (2007).

²⁸⁴ Jung Hur et al., *Effects of Hub-and-Spoke Free Trade Agreements on Trade: A Panel Data Analysis*, 38 *WORLD DEVELOPMENT* 1105 (2010); see, e.g., Carsten Kowalczyk & Ronald J. Wonnacott, *Hubs and Spokes, and Free Trade in the Americas* 2 (Nat’l Bureau Econ. Res., Working Paper No. 4198, 1992) (“In August, 1992, Canada, Mexico and the United States presented a free trade agreement (FTA) to cover a North American market with a combined GNP approaching \$7 trillion and an annual trade in goods and services among its members exceeding \$270 billion. Although this agreement is essentially in a trilateral PTA format, full ratification by all three countries is not guaranteed. If Canada were not to ratify, the result could be a Mexico-U.S. bilateral ETA, creating a hub-and-spoke system in which the United States as the hub would have one bilateral spoke agreement with Canada (the 1989 Canada-U.S. PTA), and another with Mexico; in other words, two free trade areas overlapping on the United States.”).

²⁸⁵ PETER J. TAYLOR & BEN DERUDDER, *WORLD CITY NETWORK: A GLOBAL URBAN ANALYSIS* 15 (2015).

money laundering; banking;²⁸⁷ diplomacy;²⁸⁸ air and rail transportation and telecommunications, shipping; and postal mail systems.²⁸⁹ Hub-and-spoke networks increased as the need for multiple origin nodes to connect to multiple destination nodes in a network increased and made the point-to-point system that directly connects every origin node to every destination node inefficient and, at times, practically unattainable. The hub-and-spoke network aggregates all flow into one hub that is fully connected, or into multiple hubs that are connected via an inter-hub (hub-hub) link. When compared with a point-to-point network, the hub-and-spoke network has a smaller number of links. But since most traffic flows through the hub or through the inter-hub links, the network has quicker flow and significantly less transactional and operating costs.²⁹⁰ Networks that include hubs also have more internal hierarchy despite the typical decentralized nature of most networks.²⁹¹ Knowing the topology of a network including the presence of a hub or hubs allows us to have a better structural sense of the networks, improve our understanding of network flows, and identify the actors that are critical to network flows.

The simplest topology of a hub in a network is that of a hub-and-spoke represented by a wheel that contains the hub node in the center, linked to nodes at the outside end of each spoke.²⁹²

²⁸⁶ JANE KNIGHT, INTERNATIONAL EDUCATION HUBS: STUDENT, TALENT, KNOWLEDGE-INNOVATION MODELS 20 (2013).

²⁸⁷ TAYLOR & DERUDDER, *supra* note 285, at 26.

²⁸⁸ Ian L.G. Wadley, *U.S. and Them: Hubs, Spokes, & Integration with Reference to Transboundary Environment and Resources Issues*, 21 BERKELEY J. INT'L L. 572, 576 (2003).

²⁸⁹ Sibel Alumur & Bahar Y. Kara, *Network Hub Location Problems: The State of the Art*, 190 EUROPEAN J. OPERATIONAL RES. 1, 13 (2008); *see* BURGHOUWT, *supra* note 283, at 2–3 (arguing that after the United States deregulation most major U.S. airline dropped their point-to-point structures and introduced hub-and-spoke networks instead) (“These are concentrated spatially around one or more hub airports where passengers can transfer to their connecting flights within a limited time window In a highly competitive market, hub-and-spoke systems offer an airline the opportunity to benefit from certain cost and demand side advantages, to deter entry, and to exercise some bureaucratic control over the hub airport.”); *see also* Ben-Yosef, *supra* note 270, at 327.

²⁹⁰ Yu An et al., *The Reliable Hub-and-Spoke Design Problem: Models and Algorithms*, 77 TRANSPORT RES. PART B: METHODOLOGICAL 103 (2015).

²⁹¹ PETER J. TAYLOR & BEN DERUDDER, WORLD CITY NETWORK: A GLOBAL URBAN ANALYSIS 26 (2015).

²⁹² O’Kelly, *supra* note 280, at 172.

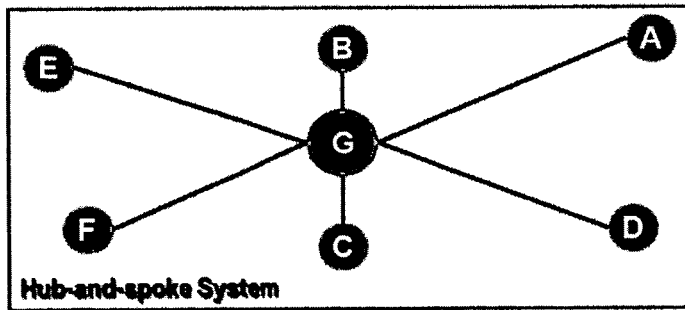

Figure 13

The central hub in this network enjoys optimal connectivity as it connects to all nodes through the spokes and is primarily responsible for the total connectivity in a hub-and-spoke network. The outside nodes have minimal connectivity, connecting mainly through the hub, and not to each other. We can categorize hubs into three main topologies based on the remaining structural qualities of the network, as represented in Figure 14 below. In centralized networks, a central hub resembles a star topology. The central node of the star is the hub, and all traffic originates from it or flows through it. In a decentralized network, there are multiple smaller centralized hubs. And finally, in a distributed network, there are no centralized hubs but there are hubs that are distributed more evenly across the network.²⁹³

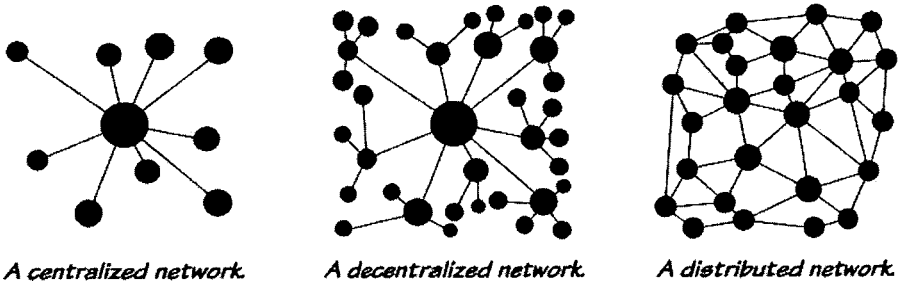
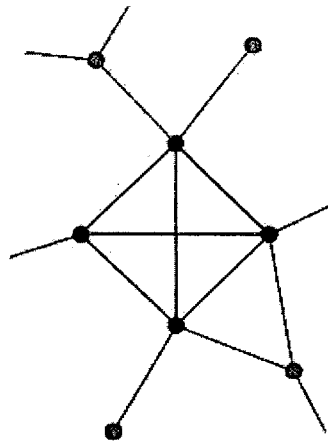

Figure 14

²⁹³ See generally ALBERT-LÁSZLÓ BARABÁSI, LINKED: HOW EVERYTHING IS CONNECTED TO EVERYTHING ELSE AND WHAT IT MEANS FOR BUSINESS, SCIENCE, AND EVERYDAY LIFE (2003).

c. Cliques

While the above topologies look at the network as a whole, we can also analyze the network from the perspective of its “sub-cultures.” Any numerically smaller neighborhoods of nodes, such as dyads and triads, are considered a sub-culture with a corresponding substructure. The main approach to understanding the structure of a network’s subculture is to measure the density of the connection of the nodes in the subculture. When every node in this substructure is connected to every other node and no other nodes can be added to it without making it less connected, we define this denser cluster as a “clique.”²⁹⁴ For example, a set of six nodes in a network is a clique if and only if each of these six nodes is directly connected to the other five and there is no other node anywhere in the network that could be added to make a group of six connected nodes instead of five. A clique indicates a highly cohesive subgroup whose nodes are highly connected—a group of classmates in a high school for instance.



IV. CONCLUSION & NEXT RESEARCH STEPS

The Westphalian model of international law has been slow and reluctant in identifying and assessing the effects of non-state actors in international law making.²⁹⁵ The partiality of legal personality may, in part, explain this inertia. The discourse used in international law is evidence of the central bias that holds the state as the main, and, at times, sole point of reference in international law making. As Philip Alston suggested, international law suffers from the “not-a-cat-syndrome” in its reference to

²⁹⁴ Hanneman & Riddle, *supra* note 180, at 365.

²⁹⁵ Celia R. Taylor, *A Modest Proposal: Statehood and Sovereignty in a Global Age*, 18 U. PA. J. INT’L ECON. L., 745, 746 (1997).

“non-state actors” as “non-state.”²⁹⁶ This marginalizes the scope of research and reinforces “the assumption that the state is the only central actor.”²⁹⁷ Other disciplines have been quicker or perhaps less resistant to recognize the transition from a hierarchical structure to a network one, and to embrace networks, either mixed with other structures, or in isolation. The analytic questions posed by other disciplines relating to their networks and methodological processes have much to offer to a nascent network analysis of international law. They can help us learn to recognize networks in various parts of life and law. Being able to adjust our mental lenses provides us with an extra set, the set of networks, that can complement existing viewpoints, offer a more nuanced description of international legislative action, and help answer faltering questions.

Social scientists have, for years, developed a set of methods to study patterns of connection and social relations. They have used these methods to approach many classic problems premised on relation and connection. Applying these methods beyond the field of social sciences can enrich our understanding of other fields, such as law. Social network analysis is a valuable tool for identifying and mapping actors’ relationships by providing a descriptive account of the nature and effects of the networks these actors are involved in. It offers a way to quantify the impact of actors in the making of international law but also tailor networked solutions to existing international problems through legislative action. By applying a series of metrics and algorithms, social network analysis can offer a more empirically comprehensive analysis of international law making and complement existing or proposed theoretical frameworks.

By means of this Article, I have aimed to show how the tools of network analysis describe the relations between actors in a network, and how they can be applied on different relational and networked contexts such as those of international legislative action. Becoming more familiar with these methods will help see the problems and possibilities of international law making in new ways. These methods, however, are only tools. The next step for future research on the intersection between international law and network analysis is to apply the methods and frameworks to specific networks that emerge in international law making to address international problems through international normative development such as treaty, customary international law, or even soft law.

Who are the actors responsible for the making of international law today? Which of those actors matter most, and why? What type of synergies do they form in the making of international law? Can we map

²⁹⁶ Alston, *supra* note 55, at 3.

²⁹⁷ *Id.*

the development of international law norms by configuring the relationships among these actors? What can we learn about the emergence, crystallization, and decline of international law norms from looking at these interactions? Are networks more effective at putting forward normative developments in international law, and under what terms? What can these insights offer to current and future international legislative action? Network analysis not only allows us to measure and map these new dynamics but also provides the springboard on which to build a new framework for international legislative action. Network analysis paints a much clearer picture of whom to call upon when putting forward a legislative agenda, when to introduce a normative prescription, and how to best diffuse it based on the actors involved in each legislative process. Network analysis also helps us determine the most powerful actors or the leaders in various networks, and to quantify the effect of their position to normative development. Finally, network analysis allows us to map how actors influence each other's normative preferences and outcomes, the preferences and outcomes of their networks and other networks, what they learn from each other, and how they are likely to act based on the structures they are embedded in.

International law has been slow in systematically addressing issues of method. International law making is one of the areas that most requires methodological insight, conceptual clarity, and legal certainty. Methodological advances in this field can significantly contribute to ongoing normative and procedural debates, enlighten future law and policy making, and increase legal certainty. Understanding and integrating these insights is critical to mapping existing and future successful international legislative action. These are just some of the many avenues for future research that have the potential to clarify the landscape of international lawmaking using the methodological lens of network theory.

